

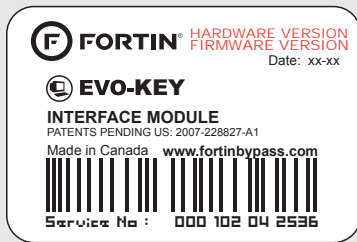

High encrypted key immobilizer bypass module.
 Module de contournement de clé hautement cryptée.

HONDA / ACURA

Guide # 14501

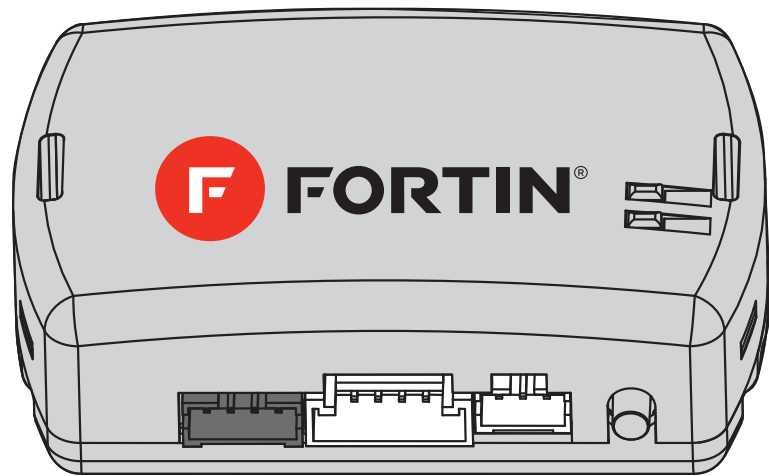

Module label | Étiquette sur le module

Notice: Updated Firmware and Installation Guides

Updated firmware and installation guides are posted on our web site on a regular basis. We recommend that you update this module to the latest firmware and download the latest installation guide(s) prior to the installation of this product.

Notice: Mise à jour microprogramme et Guides d'installations

Des mises à jour du Firmware (microprogramme) et des guides d'installation sont mis en ligne régulièrement. Vérifiez que vous avez bien la dernière version logiciel et le dernier guide d'installation avant l'installation de ce produit.



TECH SUPPORT
 TEL.: 514-255-HELP (4357)
 1-877-336-7797

www.fortinbypass.com

WEB UPDATE | MISE À JOUR INTERNET



ADDENDUM GUIDE
 REV.: 20141210

DESCRIPTION | DESCRIPTION

4-PIN CONNECTOR:

Data-Link & Internet Firmware Update Connector*
Data-Link & Connecteur pour mise à jour par internet*
(White | Blanc)

Connect with the FLASH-LINK UPDATER to update the firmware by Internet.
Connectez avec le FLASH LINK UPDATER pour les mises à jour du module par internet.

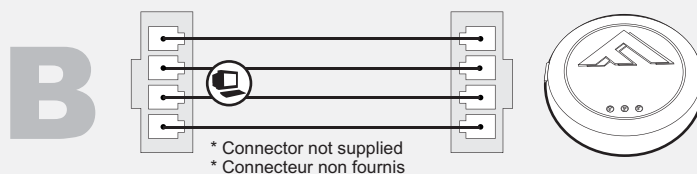

FLASH LINK UPDATER
Sold separately
Vendu séparément

* Connector not supplied
* Connecteur non fournis

B

4 PIN CONNECTOR:

DATA-LINK
(BLACK | NOIR)

12V Battery (+)
12V Batterie (+)

	Red Rouge	B1
Ground (-) Masse (-)	Black Noir	B2
DATA	Blue Bleu	B3
DATA	White Blanc	B4

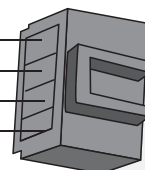
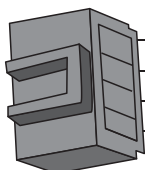

A

6 PIN CONNECTOR:

MAIN HARNESS | HARNAIS PRINCIPAL
(WHITE | BLANC)

(-)Ground While Running
(-)Masse d'activation

	Dk.Blue Bleu Foncé	OUT	A1
(+) Ignition	Yellow Jaune	IN	A2
KeySens	White/Black Blanc/Noir	OUT	A3
(+/-) Data3	Red/Blue Rouge/Bleu	IN	A4
(+/-) Data1	Lt.Blue/Black Bleu Pâle/Noir	IN/OUT	A5
(+/-) Data2	Lt.Blue Bleu Pâle	IN/OUT	A6

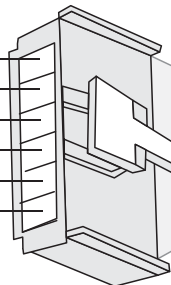

D

3 PIN CONNECTOR:

RELAY | RELAIS
(WHITE | BLANC)

NC2	White/Green Blanc/Vert	D1
NO2	White/Blue Blanc/Bleu	D2
COMM2	White/Red Blanc/Rouge	D3

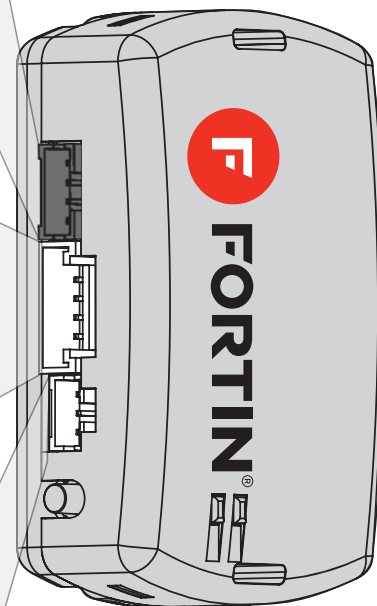
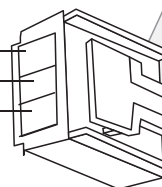

LED | DEL

Yellow | Jaune: **IGNITION ON**
Red | Rouge : **REMOTE START ON**

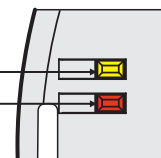

INSTALLATION PROCEDURE | PROCÉDURE D'INSTALLATION

1

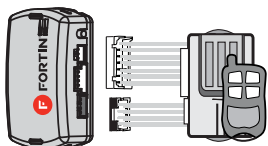

Determine if the remote-starter or alarm system supports 2-way Data-Link.

Déterminez si le démarreur à distance ou système d'alarme est compatible en Data-Link 2-voies.

**WITH DATA-LINK
AVEC DATA-LINK**

In order to utilize this type of connection the remote-starter or alarm-system must be compatible with the **Fortin Data-link protocol**. Consult the installation guide or visit www.fortinbypass.com/datalink/ for more information.

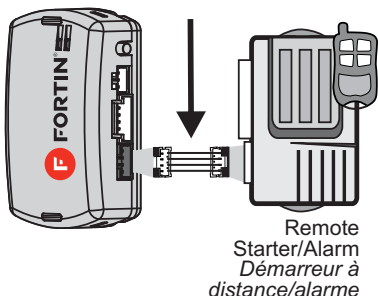

Le démarreur à distance ou le système d'alarme doit être compatible avec le **protocole Data-link Fortin** pour ces branchements. Consultez le guide d'installation du démarreur à distance ou du système d'alarme ou visitez le www.fortinbypass.com/datalink/ pour plus d'informations.

**WITH OUT DATA-LINK
SANS DATA-LINK**

For all other remote-starters or alarm-systems perform the following connections.

Pour tout autres types de démarreurs à distance ou d'alarme, effectuez les branchements suivants.

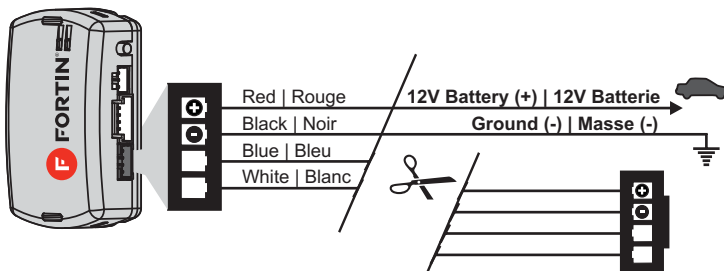

1 Cut off one plug of the 4 Pin Data-Link connector

1 Coupez l'extrémité du connecteur 4 pins Data-Link

2 Connect the Red wire to +12V

2 Connectez le fil rouge au 12V

3 Connect the Black wire to Ground

3 Connectez le fil noir à la masse du véhicule.

2

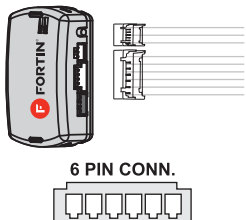

Make the connections:

Faire les branchements:

6-pin Connector (White):
Make the connections associated with the vehicle from the VEHICLE FIT GUIDE.

6-pins Connecteur (Blanc):
Effectuez les branchements associés au véhicule dans le GUIDE DES VÉHICULES.

3 PIN CONN.

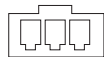

4-pin Connector RELAY (White):
Make the connections (if required)

5-pins Connecteur RELAIS (Blanc):
Effectuez les branchements.(Si nécessaire)

3



PROGRAMMING PROCEDURE

PROCÉDURE DE PROGRAMMATION

Determine the programming procedure required for the vehicle in the VEHICLE FIT GUIDE.

Déterminez le type de programmation selon votre véhicule dans le GUIDE DES VÉHICULES.

Connection number Numéro de connexion	Vehicle(s) associated with the procedure Véhicule(s) associé(s) à la configuration	Programming number Numéro de programmation
CONNECTION #	VEHICLE MAKE MODEL YEAR	PROGRAM: #

VEHICLE FIT GUIDE | GUIDE DES VÉHICULES

VEHICLE VEHICULES	YEARS ANNÉES	Connection	Programming
ACURA			
CSX	2006-2011	2	1
EL 1.7	2001-2005	3	1
ILX <i>Push-to-Start</i>	2013-2015	Guide # 18331	
MDX	2003-2006	3	1
	2007-2013	2	1
	<i>Push-to-Start</i> 2014-2015	Guide # 18301	
RDX	2007-2013	2	1
	<i>Push-to-Start</i> 2013-2015	Guide # 18351	
RL	1998-2004	4	1
	2005-2012	5	1
RLX <i>Push-to-Start</i>	2014	Guide # 18371	
RSX	2002-2006	3	1
TL	2004-2008	3	1
	2009-2013	1	1
	<i>Push-to-Start</i> 2009-2014	Guide # 18321	
TSX	2004-2008	3	1
	2009-2013	1	1
ZDX	2010-2013	2	1

VEHICLE VEHICULES	YEARS ANNÉES	Connection	Programming
HONDA			
Accord	2003-2007	3	1
	2008-2012	1	1
	2013-2015	Guide # 16271	
<i>Accord Hybrid</i>	2005-2007	3	1
<i>Accord Crosstour</i>	2010-2012	1	1
<i>Push-to-Start</i>	2013-2015	Guide # 18371	
<i>Hybrid Push-to-Start</i>	2013-2015	Guide # 18371	
Civic or Civic Hybrid	2001-2005	3	1
	2006-2011	2	1
	2012-2014	6	1
	<i>Push-to-Start</i> 2014-2015	Guide # 18311	
CR-V	1998-2001	3	1
	2002-2006	3	1
	2007-2011	2	1
	2012-2015	6	1
	<i>Push-to-Start</i> 2015	Guide # 23611	
CR-Z Hybrid	2011-2014	2	1
Element	2003-2010	3	1
Fit	2006-2008	3	1
	2009-2014	2	1
Insight	2010-2014	2	1
Odyssey	2005-2010	3	1
	2011-2014	1	1
	<i>Push-to-Start</i> 2014-2015	Guide # 18321	
Pilot	2005-2008	3	1
	2009-2015	1	1
Prelude	1997-2001	4	1
Ridgeline	2006-2014	3	1
S2000	2004-2007	3	1

CONNECTION 1

ACURA / HONDA

GO PROGRAM.: 1

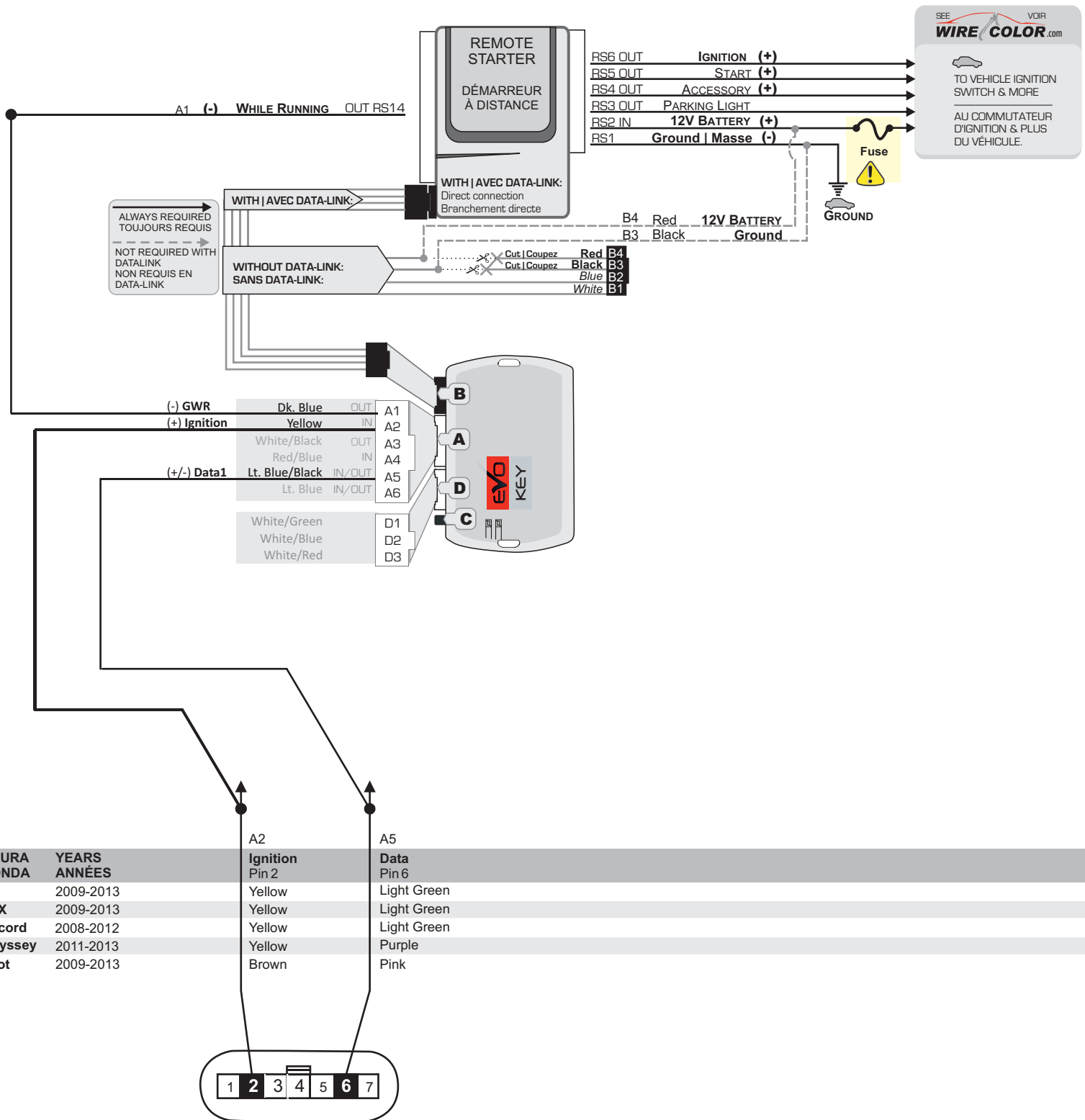

At steering column immobilizer control unit.
À la colonne de direction au module de contrôle de la clé à puce.

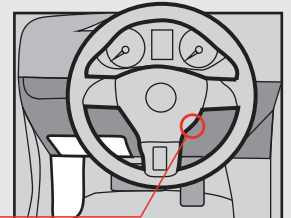
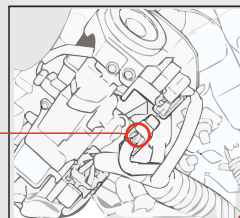

CONNECTION 2

ACURA / HONDA

GO PROGRAM.: 1

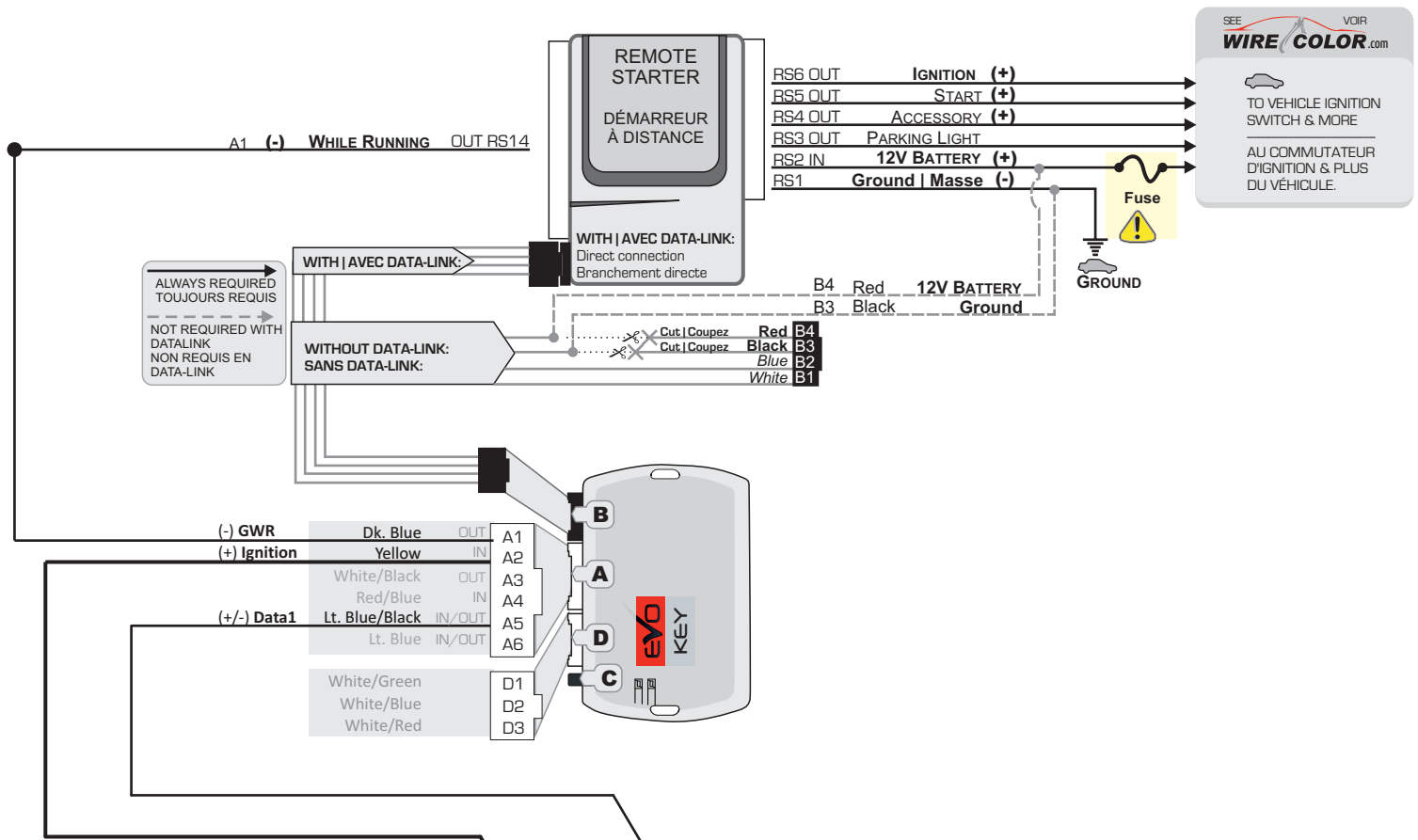

ACURA HONDA	YEARS ANNÉES	A2 Ignition Pin 2	A5 Data Pin 3
CSX	2006-2011	Yellow	Lt Green
RDX	2007-2012	Yellow	Lt Green
MDX	2007-2013	Lt Green	Brown
ZDX	2010-2013	Yellow	Lt Green
Civic	2006-2011	Yellow	Lt Green
Hybrid	2006-2011	Yellow	Lt Green
CR-V	2007-2011	Lt Blue	Green
CR-Z	2009-2013	Brown	Pink
Fit	2009-2013	Red	Green
Insight	2010-2013	Red	Lt Green

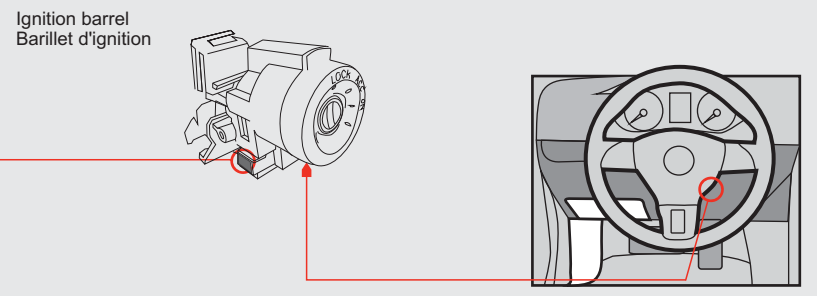
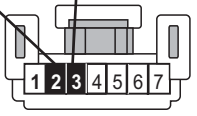

CONNECTION 3

ACURA / HONDA

GO PROGRAM.: 1

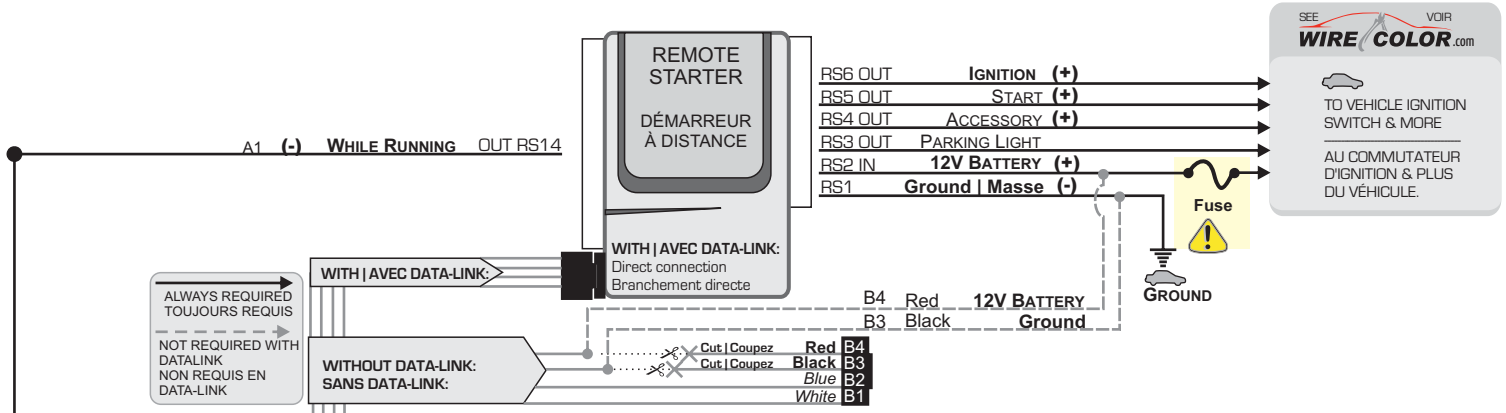

ALWAYS REQUIRED
TOUJOURS REQUIS

NOT REQUIRED WITH
DATA LINK
NON REQUIS EN
DATA LINK

WITH | AVEC DATA-LINK:
Direct connection
Branchement direct

WITHOUT DATA-LINK:
SANS DATA-LINK:

Cut | Coupez Red B4
Black B3
Blue B2
White B1

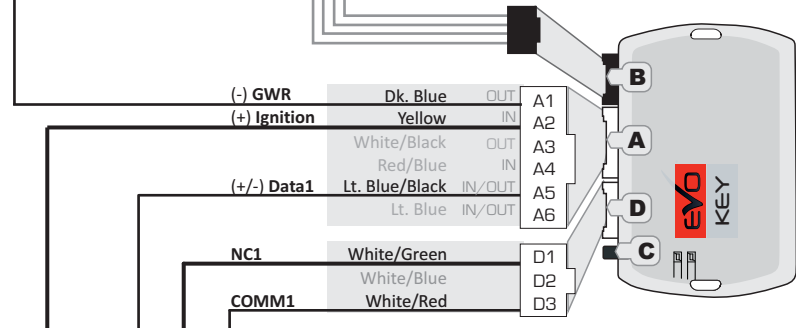

YEARS ANNÉES	A5 Data Pin 2	D1 Security Light Pin 5	A2 Ignition Pin 6
1.7EL	2001-2005 Red/Blue	Blue/Orange	Yellow/Black
MDX	2003-2006 Red	Pink	Green/White
RSX	2002-2003 Red/Blue	Blue/Orange	Yellow/Black
	2004-2006 Red/Blue	Blue/Orange	Black/Yellow
Civic / Hyb	2001-2005 Red/Blue	Blue/Orange	Yellow/Black
CR-V	2002-2004 White	Blue/Orange	Yellow/Black
	2005-2006 White	Blue/Orange	Black/Yellow
Element	2003-2010 White	Blue/Orange	Black/Yellow
Fit	2006-2008 Lt.Green/Black	Red/Black	Black/Yellow
Pilot	2005-2008 Red/Green	White/Blue	Red/White
S-2000	2004-2007 Red/Blue	Pink	Black/Yellow
TL	2004-2006 Red/Blue	Blue/Orange	Black/Green
	2007-2008 Yellow	Orange	Black/Green
TSX	2004-2005 Red/Blue	Blue/Orange	Black/Yellow
	2006-2008 Yellow	Orange	Black/Yellow
Accord	2003-2007 Red/Blue	Blue/Orange	Black/Yellow
Hybrid	2005 Yellow	Red	Black/Yellow
Hybrid	2006-2007 Yellow	Red	Black/Yellow
Odyssey	2005-2010 Red/Blue	Blue/Orange	Black/Yellow
Ridgeline	2006-2013 Red/Blue	Blue/Orange	Black/Green

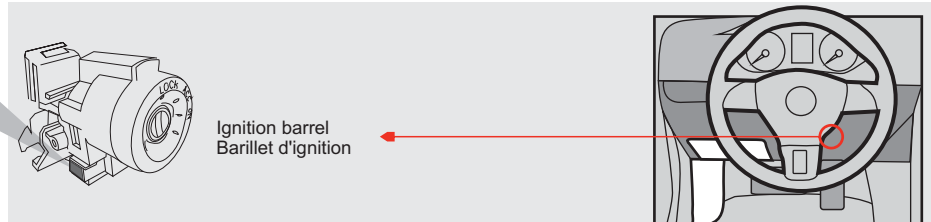

CONNECTION 4

ACURA RL 1998-2004 / HONDA PRELUDE

GO PROGRAM.: 1

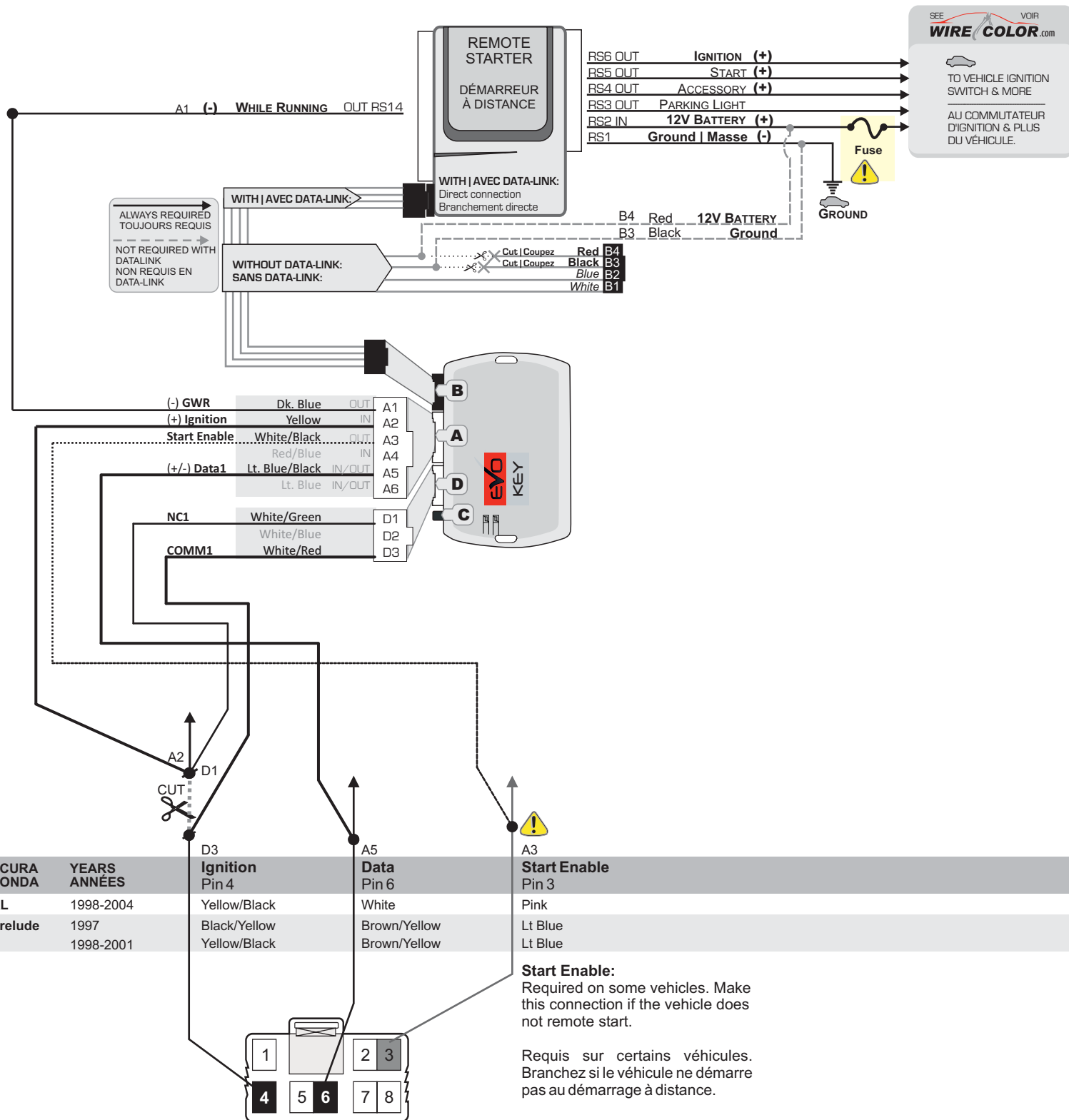

CONNECTOR A

Immobilizer module
 Located at the base of the steering column

Module d'immobilisation situé à la base de la colonne de direction

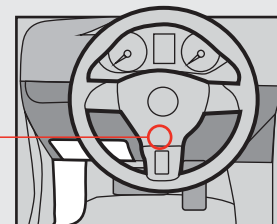
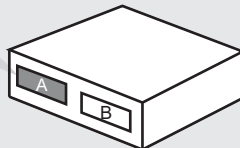

CONNECTION 5

ACURA RL 2005-2012

GO PROGRAM.: 1

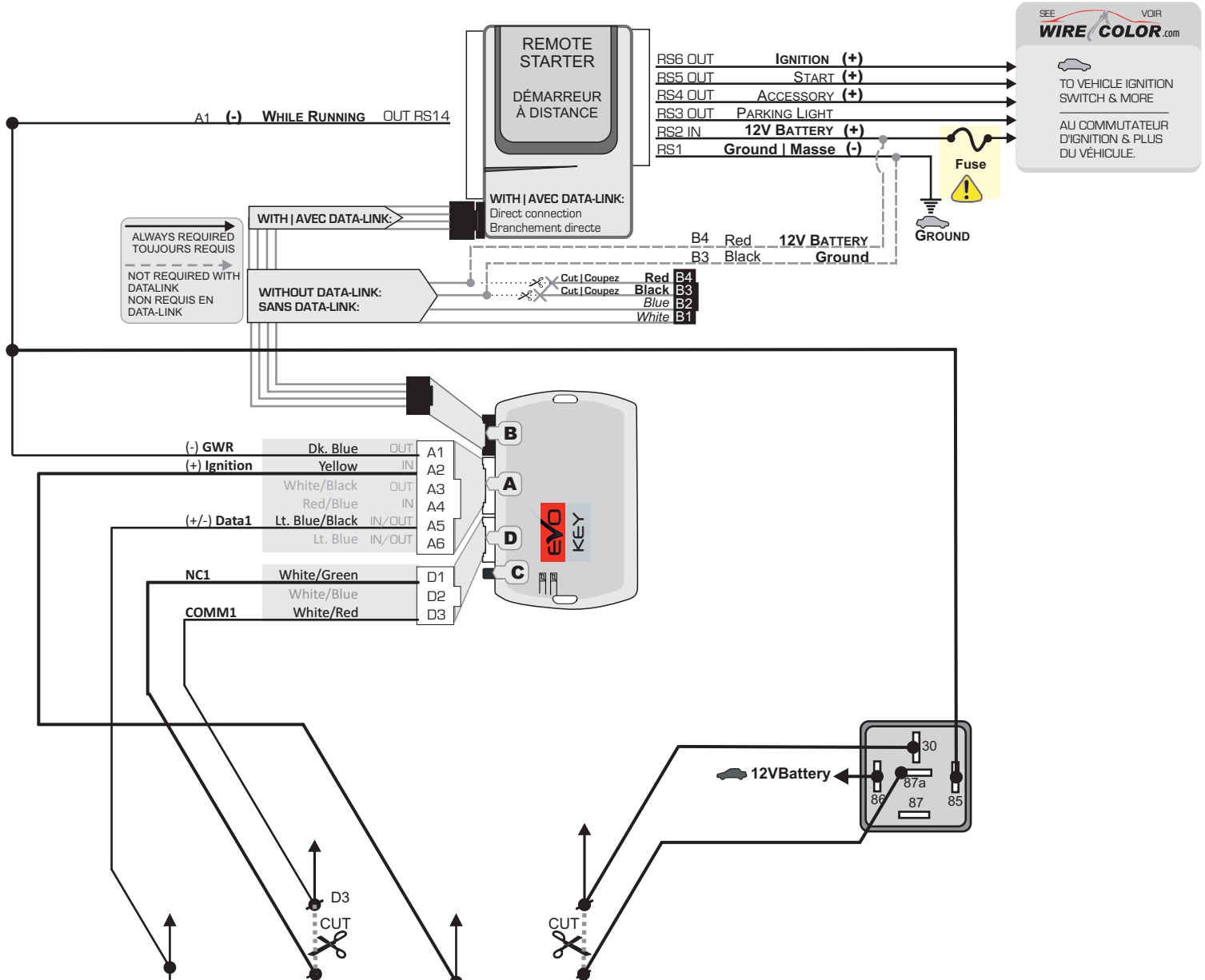

SEE WIRE COLOR.com VOIR

TO VEHICLE IGNITION SWITCH & MORE
AU COMMUTATEUR D'IGNITION & PLUS DU VÉHICULE.

ACURA	YEARS ANNÉES	Data Pin 2	Security Light Pin 5	Ignition Pin 6
RL	2005	Lt Green	Blue	Pink
	2006	Orange	Red	Red
	2007-2010	Orange	Red	Red

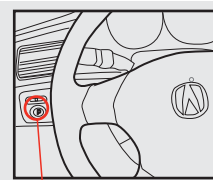
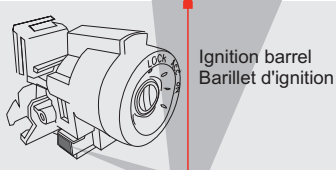

Keyless access indicator: Indicateur d'accès sans clé:
Grey connector located behind the electric mirror switch at left of the steering wheel.

Connecteur épissure Gris situé derrière le commutateur de miroir élect. à gauche de la colonne de direction.

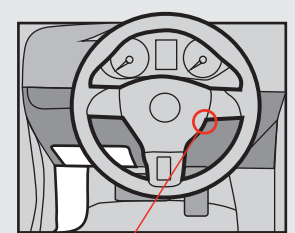

CONNECTION 6

HONDA CRV 2012-2014

GO PROGRAM.: 1

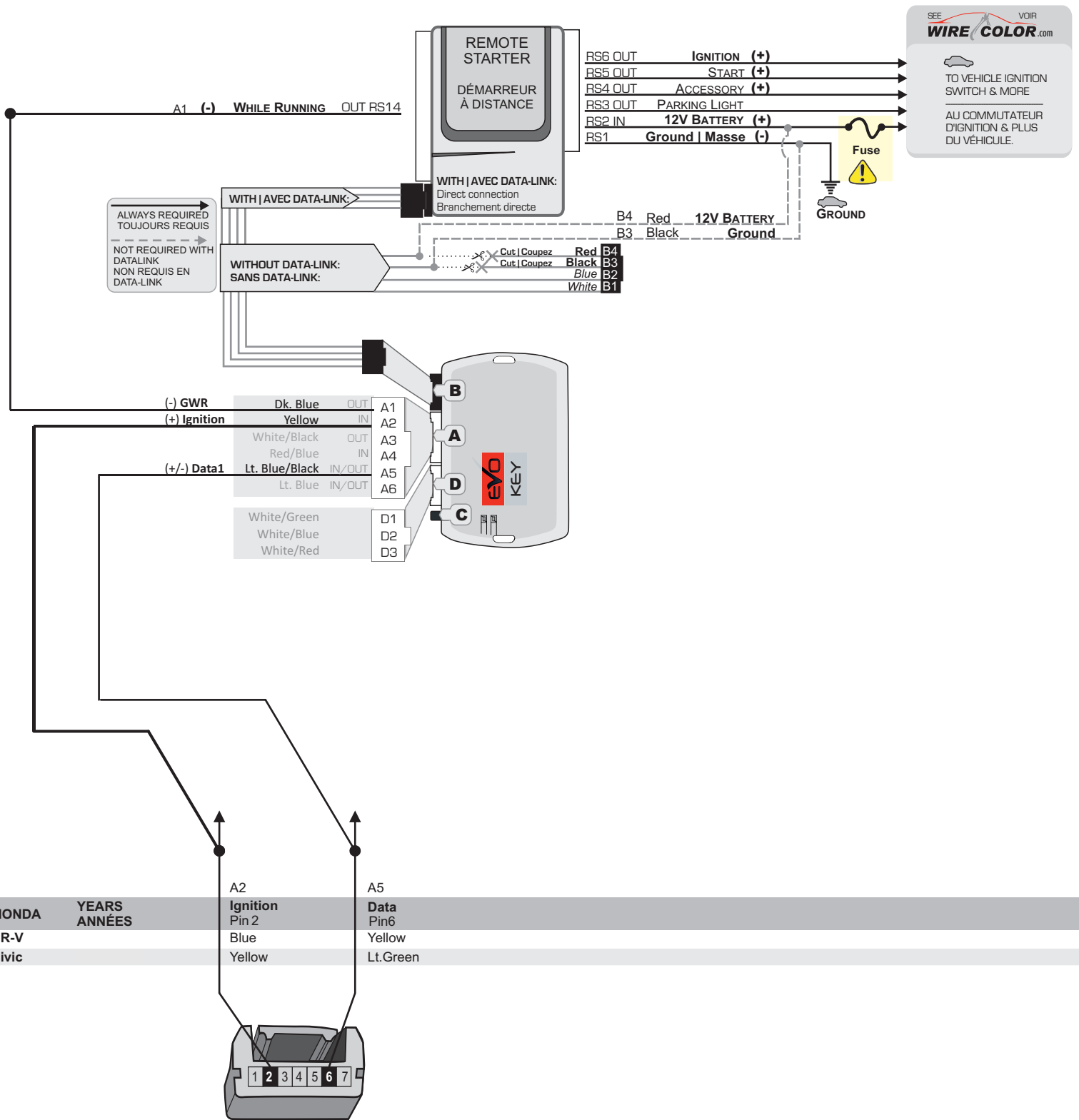

At steering column immobilizer control unit.
À la colonne de direction au module de contrôle de la clé à puce.

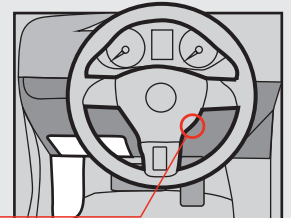
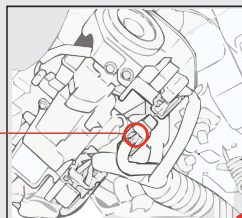

PROGRAMMING PROCEDURE | PROCÉDURE DE PROGRAMMATION

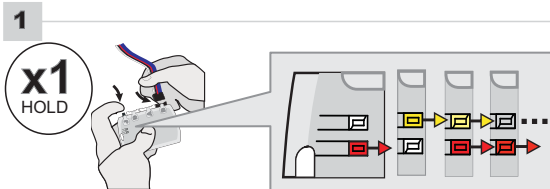

Press and hold the programming button:
Insert the 4-Pin (Data-link Connector) connector.

Appuyez et maintenir enfoncé le bouton de programmation:
Insérez le connecteur 4 pins (Connecteur Data-Link)

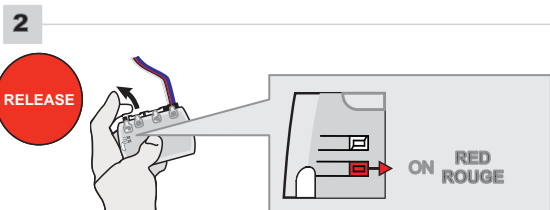

Release the programming button when the LED is RED.

Relâchez le bouton de programmation quand la DEL est ROUGE.

If the LED is not solid RED disconnect the 4-Pin connector (Data Link) and go back to step 1.

Si le DEL n'est pas ROUGE débranchez le connecteur 4 pins (Connecteur Data Link) et allez au début de l'étape 1

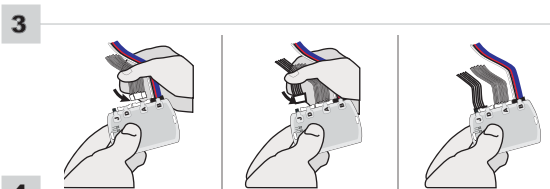
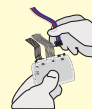

Insert the required remaining connectors.

Insérez les connecteurs requis restants.

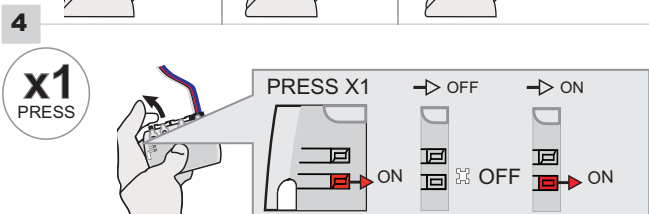

Press and release the programming button once (1x).

Appuyez et relâchez 1 fois le bouton de programmation.

↳The RED LED will turn OFF and then back ON.

↳La DEL ROUGE s'éteint et se rallume.

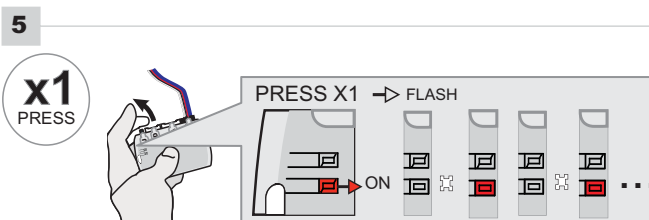

Press and release the programming button once (1x).

Appuyez et relâchez 1 fois le bouton de programmation.

↳The RED LED will flash 1 once each second.

↳La DEL ROUGE clignote 1 fois chaque seconde.

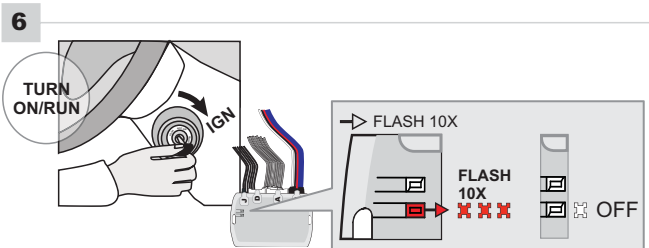

Turn the Ignition to the ON/RUN position.

Tournez la clé en position ignition (ON).

↳The RED LED will flash rapidly ten (10) times.

↳La DEL ROUGE clignotera dix (10) fois rapidement.

↳The RED LED will turn off.

↳La DEL ROUGE s'éteint.

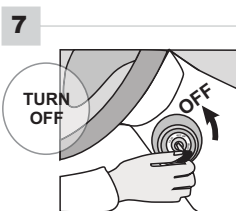

Turn the Ignition to the OFF position.

Tournez la clé à OFF.



The module is now programmed.

Le module est programmé.

EVO

KEY

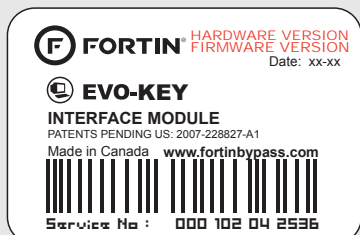

Module label | Étiquette sur le module

Notice: Updated Firmware and Installation Guides

Updated firmware and installation guides are posted on our web site on a regular basis. We recommend that you update this module to the latest firmware and download the latest installation guide(s) prior to the installation of this product.

Notice: Mise à jour microprogramme et Guides d'installations

Des mises à jour du Firmware (microprogramme) et des guides d'installation sont mis en ligne régulièrement. Vérifiez que vous avez bien la dernière version logiciel et le dernier guide d'installation avant l'installation de ce produit.

WARNING

The information on this sheet is provided on an (as is) basis with no representation or warranty of accuracy whatsoever. It is the sole responsibility of the installer to check and verify any circuit before connecting to it. Only a computer safe logic probe or digital multimeter should be used. FORTIN ELECTRONIC SYSTEMS assumes absolutely no liability or responsibility whatsoever pertaining to the accuracy or currency of the information supplied. The installation in every case is the sole responsibility of the installer performing the work and FORTIN ELECTRONIC SYSTEMS assumes no liability or responsibility whatsoever resulting from any type of installation, whether performed properly, improperly or any other way. Neither the manufacturer or distributor of this module is responsible of damages of any kind indirectly or directly caused by this module, except for the replacement of this module in case of manufacturing defects. This module must be installed by qualified technician. The information supplied is a guide only. This instruction guide may change without notice. Visit www.fortinbypass.com to get the latest version.

MISE EN GARDE

L'information de ce guide est fournie sur la base de représentation (telle quelle) sans aucune garantie de précision et d'exactitude. Il est de la seule responsabilité de l'installateur de vérifier tous les fils et circuits avant d'effectuer les connexions. Seuls une sonde logique ou un multimètre digital doivent être utilisés. FORTIN SYSTÈMES ÉLECTRONIQUES n'assume aucune responsabilité de l'exactitude de l'information fournie. L'installation (dans chaque cas) est la responsabilité de l'installateur effectuant le travail. FORTIN SYSTÈMES ÉLECTRONIQUES n'assume aucune responsabilité suite à l'installation, que celle-ci soit bonne, mauvaise ou de n'importe autre type. Ni le manufacturier, ni le distributeur ne se considèrent responsables des dommages causés ou ayant pu être causés, indirectement ou directement, par ce module, excepté le remplacement de ce module en cas de défectuosité de fabrication. Ce module doit être installé par un technicien qualifié. L'information fournie dans ce guide est une suggestion. Ce guide d'instruction peut faire l'objet de changement sans préavis. Consultez le www.fortinbypass.com pour voir la plus récente version.

Copyright © 2006-2012, FORTIN AUTO RADIO INC ALL RIGHTS RESERVED PATENT PENDING

**TECH SUPPORT**

Tél: 514-255-HELP (4357)
1-877-336-7797

**ADDENDUM GUIDE**

www.fortinbypass.com

WEB UPDATE | MISE À JOUR INTERNET

