

**REGULAR INSTALLATION
INSTALLATION RÉGULIÈRE**

 ADDENDUM - SUGGESTED WIRING CONFIGURATION
 ADDENDA - SCHÉMA DE BRANCHEMENT SUGGÉRÉ

**VEHICLE
VEHICULES**
**YEARS
ANNÉES**
CONFIGURATIONS
Vehicle functions supported in this diagram (functional if equipped) | Fonctions du véhicule supportées dans ce diagramme (fonctionnelles si équipé)

			Without doorlocks verrouillage des portes	With doorlocks INT-SL+ required Avec verrouillage des portes INT-SL+ requis	Immobilizer bypass Contournement d'immo- bilisateur	Lock	Unlock	Arm	Disarm	Trunk (open)	Parking Lights
LEXUS											
GS 350	Push-to-Start	2009-2012	1	2	•	•	•	•	•	•	•
GS 460	Push-to-Start	2009-2012	1	2	•	•	•	•	•	•	•

To control the doorlocks an **INT-SL+** module must be used. (Sold separately)
 Pour le contrôle des portes un module **INT-SL+** doit être installé. (Vendu séparément)

 FIRMWARE VERSION
 VERSION LOGICIELLE

79.[65]

MINIMUM

 To add the firmware version and the options, use the **FLASH LINK UPDATER** or **FLASH LINK MOBILE** tool, sold separately.

 Pour ajouter la version logicielle et les options, utilisez l'outil **FLASH LINK UPDATER** ou **FLASH LINK MOBILE**, vendu séparément.

Parts required (Not included)

 1x 10 Amp fuse max.
 1x Optional INT-SL+ for door locks

Pièce(s) requise(s) (Non incluse(s))

 1x fusible 10 Amp max.
 1x INT-SL+ Optionnel pour verrouillage des portes

 FIRMWARE VERSION
 VERSION DU LOGICIEL

V0.17
INT-SL+

 To control the doorlocks
 (Sold separately)
 Pour le contrôle des portes
 (Vendu séparément)

MANDATORY INSTALL | INSTALLATION OBLIGATOIRE
***HOOD PIN**

HOOD STATUS: THE HOOD PIN SWITCH MUST BE INSTALLED IF THE VEHICLE CAN BE REMOTE STARTED WITH THE HOOD OPEN, SET FUNCTION **A11** TO OFF.

A11
**OFF
NON**
**CONTACT
DE CAPOT**
STATUT DE CAPOT: LE CONTACT DE CAPOT, DOIT ÊTRE INSTALLÉ SI LE VÉHICULE PEUT DÉMARRER À DISTANCE, LORSQUE LE CAPOT EST OUVERT, PROGRAMMEZ LA FONCTION **A11** À NON.

Notice: the installation of safety elements are mandatory. The hood pin is an essential security element and must be installed.

Notice: l'installation des éléments de sécurité est obligatoire. Le contact de capot est un élément de sécurité essentiel et doit absolument être installé.

THIS MODULE MUST BE INSTALLED BY A QUALIFIED TECHNICIAN. A WRONG CONNECTION CAN CAUSE PERMANENT DAMAGE TO THE VEHICLE.

CE MODULE DOIT ÊTRE INSTALLÉ PAR UN TECHNICIEN QUALIFIÉ, TOUTE ERREUR DANS LES BRANCHEMENTS PEUT OCCASIONNER DES DOMMAGES PERMANENTS AU VÉHICULE.

DESCRIPTION | DESCRIPTION

④ On the top of the gloves box
En haut de la boîte à gants

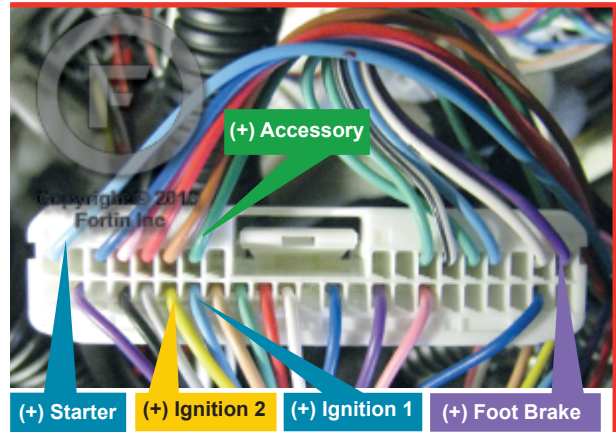

③ Parking lights switch
Commutateur de feux de stationnement



① Drivers side kick panel
Panneau latéral côté chauffeur

② ECM Driver Kick Panel ECM
ECM Panneau latéral côté chauffeur

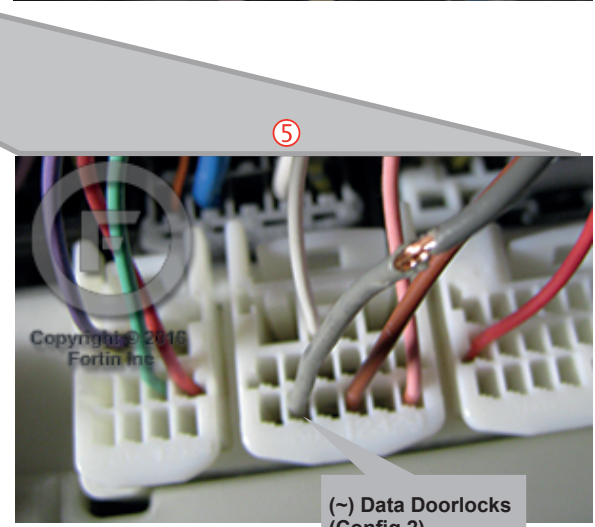
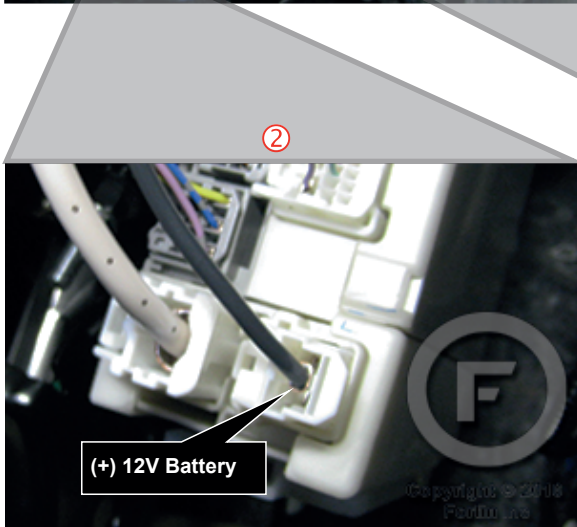
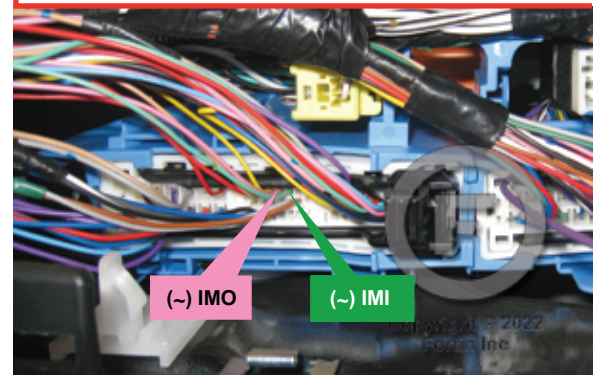
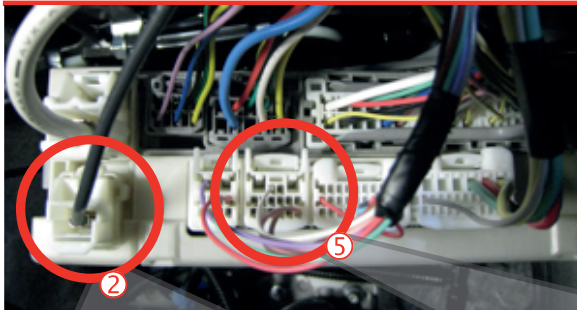

CONFIG.1 WIRING CONNECTION | GUIDE DE BRANCHEMENTS

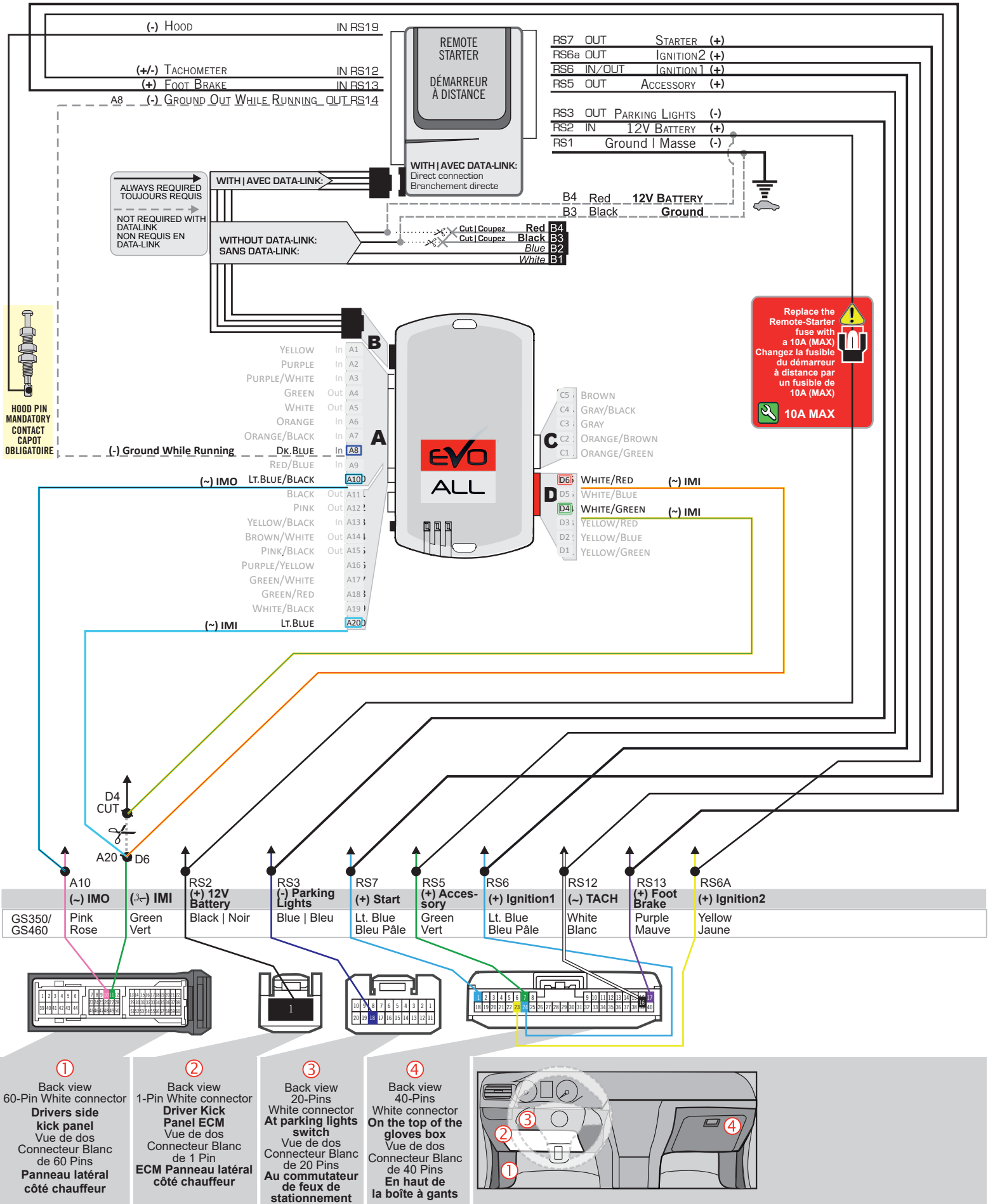

CONFIG.2 WIRING CONNECTION | GUIDE DE BRANCHEMENTS

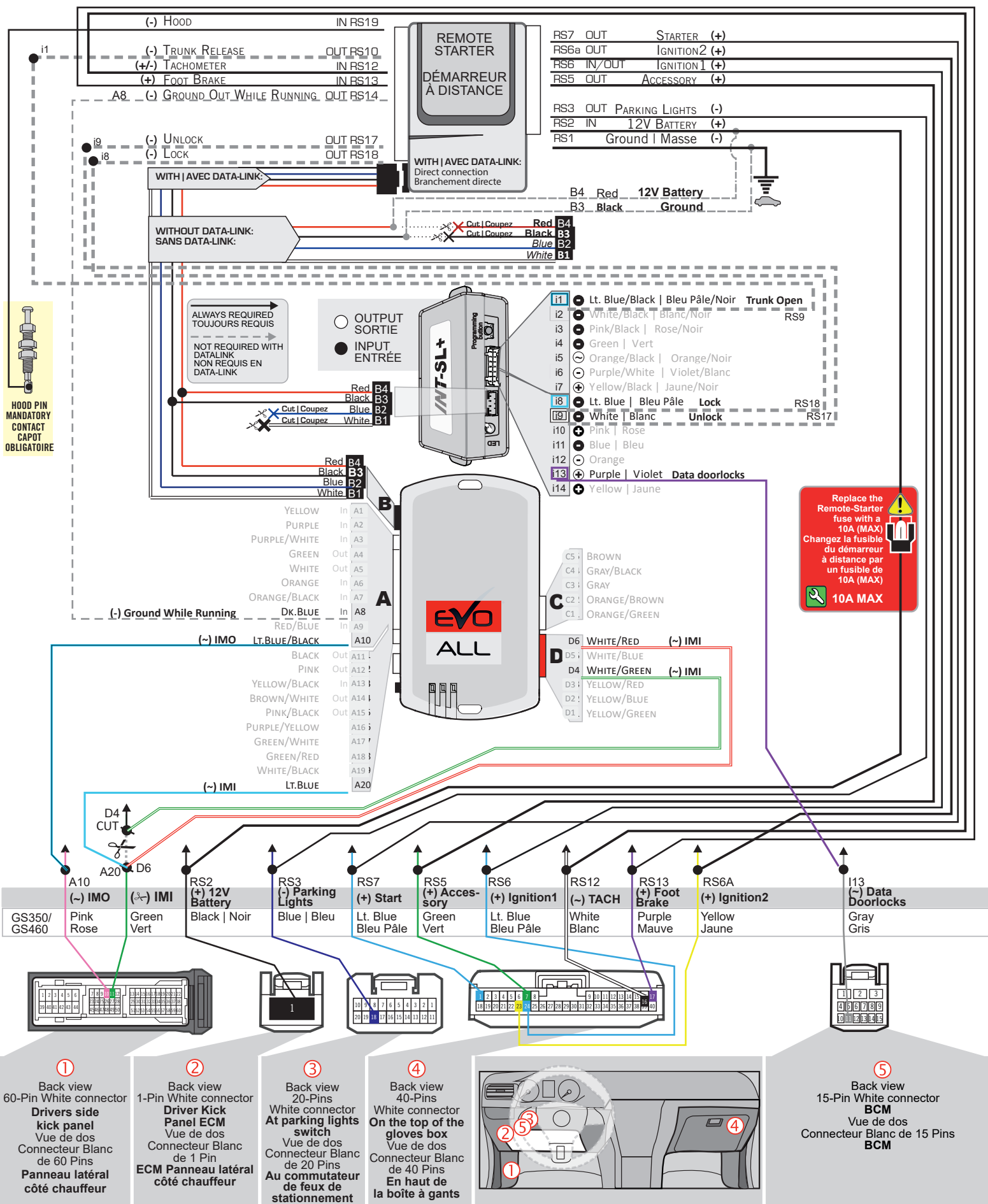

PROGRAMMING PROCEDURE | PROCÉDURE DE PROGRAMMATION

1

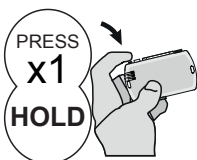

Press and hold the programming button.

Appuyez et maintenez enfoncé le bouton de programmation.

2

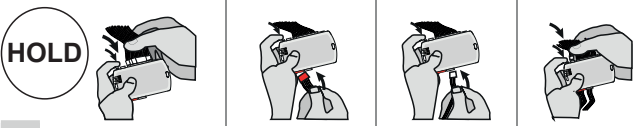

Insert the connectors:
20 pin (White),
6 pin (Red),
5 pin (White),
2 pin (White).
(If required)

Insérez les connecteurs:
20 pins (Blanc),
6 pins (Rouge),
5 pins (Blanc),
2 pins (Blanc).
(Si requis)

3



Insert the 4-Pin (Data-Link) connector.

↳ The Blue, Red, Yellow and Blue & Red LEDs will alternatively illuminate.

Insérez le connecteur 4 pins (Data-Link)

↳ Les DELs Bleue, Rouge, Jaune et Bleue & Rouge s'illumineront alternativement.

4

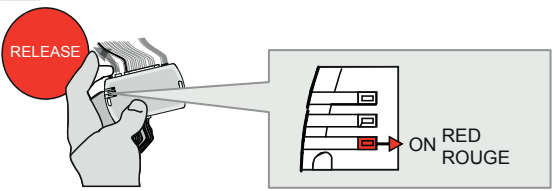

Release the programming button when the LED is RED.

Relâchez le bouton de programmation quand la DEL est ROUGE.

If the LED is not solid RED disconnect the 4 Pin connector (Data-Link) and go back to step 1.

Si le DEL n'est pas ROUGE solide débranchez le connecteur 4 pins (Data-Link) et allez à l'étape 1.

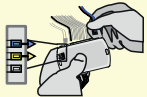

5



Press the brake pedal.

Appuyez sur la pédale de frein.

6

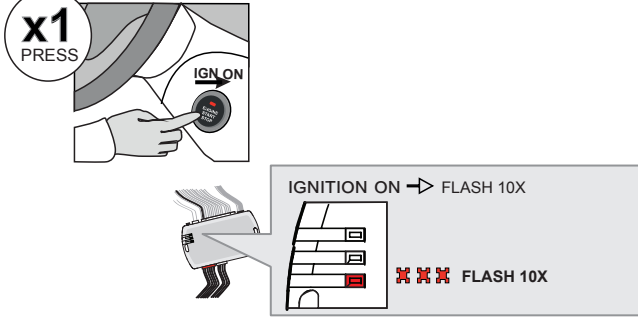

Press the Push-to-Start button once to start the engine.

↳ The RED LED will flash rapidly 10x times.
Key bypass programmed.

Appuyez 1 fois sur le bouton démarrage (Push-to-Start) pour démarrer le moteur.

↳ La DEL ROUGE clignotera 10x fois rapidement.
Contournement de clé programmé.

7

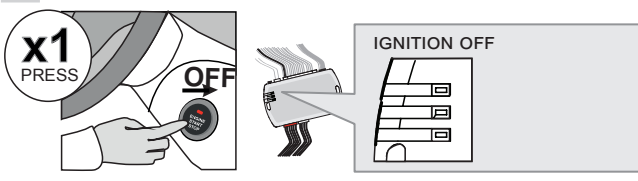

Press the Push-to-Start button once to turn off the ignition.





Appuyez 1 fois sur le bouton démarrage (Push-to-Start) pour éteindre l'ignition.





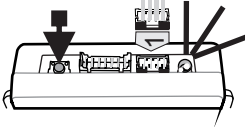
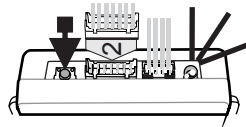

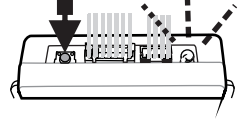
The module is now programmed.

Le module est programmé.

INT-SL PROGRAMMING PROCEDURE CONFIG.2 | PROCÉDURE DE PROGRAMMATION DU INT-SL CONFIG.2

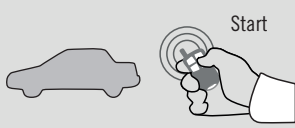
<p>1</p>  <p>Keep programming button pressed while inserting connector 1.</p> <p>Maintenez le bouton de programmation enfoncé. Insérez le connecteur 1 dans le module.</p>	<p>2</p>  <p>Insert connector 2.</p> <p>Release the programming button when the LED turns ON.</p> <p>Insérez le connecteur 2 dans le module.</p> <p>Lorsque la DEL s'allume, relâchez le bouton de programmation.</p>	<p>3</p>  <p>Press the lock button on the door.</p> <p>Appuyer sur le bouton verrouillage de la porte.</p>	<p>4</p>  <p>The LED will flash rapidly.</p> <p>La DEL clignote rapidement.</p>	 <p><i>The module is now programmed.</i></p> <p><i>Le module est programmé.</i></p>
--	---	--	---	--

REMOTE STARTER FUNCTIONALITY | FONCTIONNALITÉS DU DÉMARREUR À DISTANCE

 <p>All doors must be closed. Toutes les portes doivent être fermées</p> <p>Remote start the vehicle. Démarrez à distance.</p>	 <p>Unlock the doors with either:</p> <ul style="list-style-type: none"> • The OEM remote • The remote-starter remote <p>• Or the proximity remote</p> <p>Déverrouillez les portes avec soit:</p> <ul style="list-style-type: none"> • la télécommande d'origine • la télécommande du démarreur à distance • ou la télécommande de proximité. 	 <p>Enter the vehicle with the SMART-KEY. Entrez dans le véhicule avec la clé intelligente (SMART-Key) sur vous</p>	 <p>Press the Push-to-Start button twice to turn ON the ignition. Appuyez 2 fois sur le bouton démarrage (Push-to-Start) pour allumer l'ignition.</p>	 <p>The vehicle can now be put in to gear and driven. Vous êtes maintenant prêt à embrayer et prendre la route.</p>
---	---	--	--	--



Module label | Étiquette sur le module

Notice: Updated Firmware and Installation Guides

Updated firmware and installation guides are posted on our web site on a regular basis. We recommend that you update this module to the latest firmware and download the latest installation guide(s) prior to the installation of this product.

Notice: Mise à jour microprogramme et Guides d'installations

Des mises à jour du Firmware (microprogramme) et des guides d'installation sont mis en ligne régulièrement. Vérifiez que vous avez bien la dernière version logiciel et le dernier guide d'installation avant l'installation de ce produit.

WARNING

The information on this sheet is provided on an (as is) basis with no representation or warranty of accuracy whatsoever. It is the sole responsibility of the installer to check and verify any circuit before connecting to it. Only a computer safe logic probe or digital multimeter should be used. FORTIN ELECTRONIC SYSTEMS assumes absolutely no liability or responsibility whatsoever pertaining to the accuracy or currency of the information supplied. The installation in every case is the sole responsibility of the installer performing the work and FORTIN ELECTRONIC SYSTEMS assumes no liability or responsibility whatsoever resulting from any type of installation, whether performed properly, improperly or any other way. Neither the manufacturer or distributor of this module is responsible of damages of any kind indirectly or directly caused by this module, except for the replacement of this module in case of manufacturing defects. This module must be installed by qualified technician. The information supplied is a guide only. This instruction guide may change without notice. Visit www.fortinbypass.com to get the latest version.

MISE EN GARDE

L'information de ce guide est fournie sur la base de représentation (telle quelle) sans aucune garantie de précision et d'exactitude. Il est de la seule responsabilité de l'installateur de vérifier tous les fils et circuits avant d'effectuer les connexions. Seuls une sonde logique ou un multimètre digital doivent être utilisés. FORTIN SYSTÈMES ÉLECTRONIQUES n'assume aucune responsabilité de l'exactitude de l'information fournie. L'installation (dans chaque cas) est la responsabilité de l'installateur effectuant le travail. FORTIN SYSTÈMES ÉLECTRONIQUES n'assume aucune responsabilité suite à l'installation, que celle-ci soit bonne, mauvaise ou de n'importe autre type. Ni le fabricant, ni le distributeur ne se considèrent responsables des dommages causés ou ayant pu être causés, indirectement ou directement, par ce module, excepté le remplacement de ce module en cas de défaut de fabrication. Ce module doit être installé par un technicien qualifié. L'information fournie dans ce guide est une suggestion. Ce guide d'instruction peut faire l'objet de changement sans préavis. Consultez le www.fortinbypass.com pour voir la plus récente version.

Copyright © 2006-2018, FORTIN AUTO RADIO INC ALL RIGHTS RESERVED PATENT PENDING



TECH SUPPORT

Tél: 514-255-HELP (4357)
1-877-336-7797



ADDENDUM GUIDE

www.fortinbypass.com

WEB UPDATE | MISE À JOUR INTERNET

