



## REMOTE CAR STARTER INTERFACE



- PARTS REQUIRED**
- Factory Remote Control,
  - Remote Car Starter with 2 way Data-Link FORTIN protocol.
- Recommended:**
- CAN-SL2 for Door Locks

| VEHICLE        | YEARS |    |    |    |    | VEHICLE | YEARS |    |    |    |    |    |
|----------------|-------|----|----|----|----|---------|-------|----|----|----|----|----|
| LANDROVER      | 06    | 07 | 08 | 09 | 10 | VOLVO   | 06    | 07 | 08 | 09 | 10 | 11 |
| Freelander-LR2 |       |    |    |    |    | V70     |       |    |    |    |    |    |
| VOLVO          | 06    | 07 | 08 | 09 | 10 | XC60    |       |    |    |    |    |    |
| S80            |       |    |    |    |    | XC70    |       |    |    |    |    |    |

## WIRING / CONNECTION GUIDE

### STEP 1



Remove the key Barrel from the dash board.  
(Disassemble the cluster to access the ignition barrel)

### STEP 2

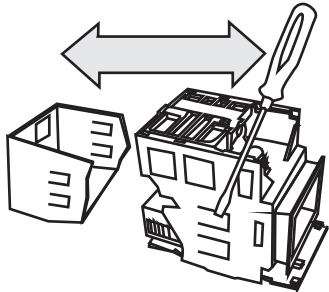

Open and remove the ignition module with a small flat screw driver.

### STEP 3

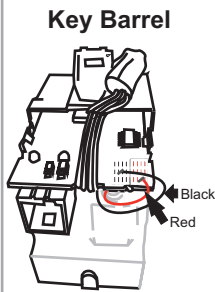

Unsolder the Red wire and the Black wire.

### STEP 4

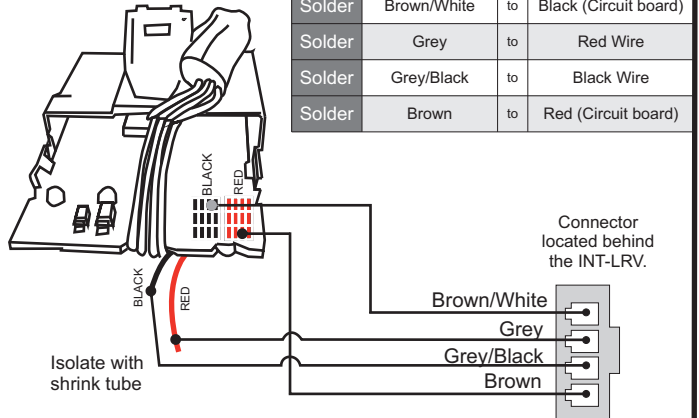

### STEP 5

**Key Barrel**  
Make 3 to 4 loops around the Key Barrel. Reassemble the ignition module

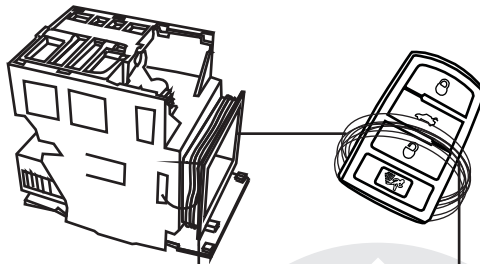
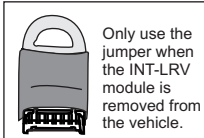

### Factory Remote Control

Make 5 to 10 loops around the Factory Remote Control and place it behind the cluster in an inaccessible location.

### STEP 6

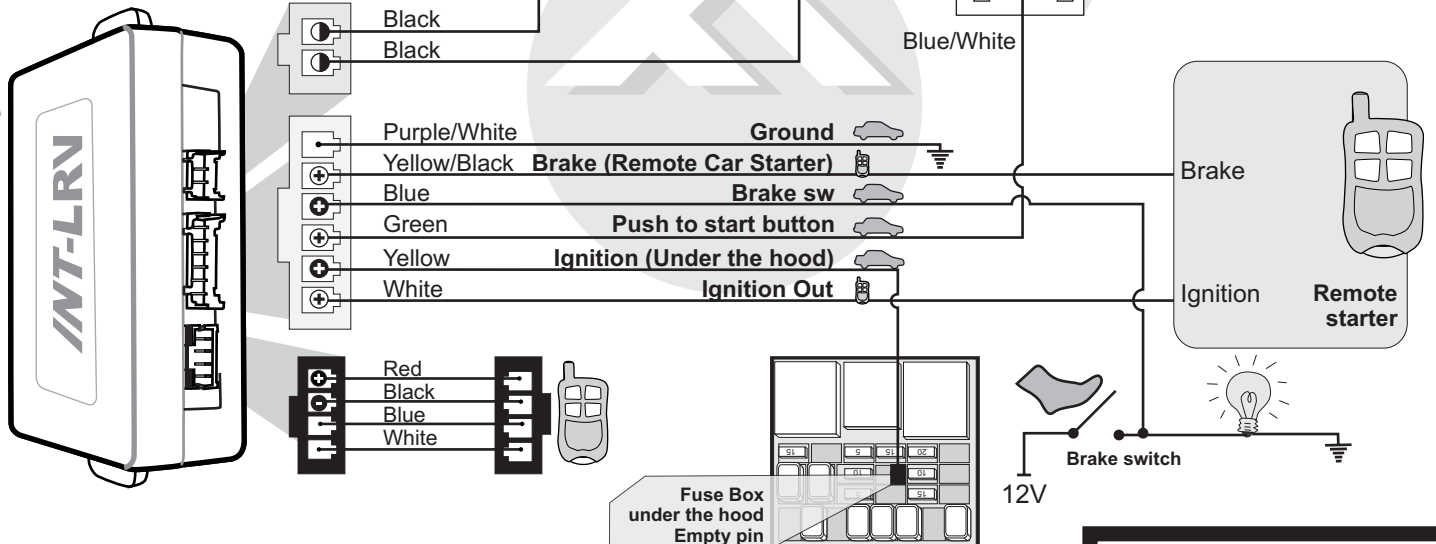
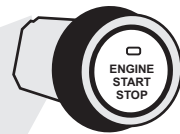

Connect wire to remote starter/Alarm    Connect wire to vehicle    ○ OUTPUT    ● INPUT    ◐ INPUT & OUTPUT

## TECHNICAL SUPPORT / INFORMATION

Neither the manufacturer or distributor of this module is responsible of damages of any kind indirectly or directly caused by this module, except for the replacement of this module in case of manufacturing defects. This module must be installed by qualified technician. This instruction guide may change without notice. Visit [www.ifar.ca](http://www.ifar.ca) to get latest version.

**Technical support:**  
TEL: 514-255-HELP (4357)  
FAX: 514-255-1367  
Web: [www.ifar.ca](http://www.ifar.ca)





## INTERFACE DÉMARREUR À DISTANCE



**PIÈCES REQUISES**

- Télécommande d'origine.
- Démarreur à distance équipé du protocole Data-Link 2-Voies FORTIN.

**Recommandé:**

- CAN-SL2 pour le verrouillage des portes

| VEHICULE         | ANNÉES            | VEHICULE     | ANNÉES            |
|------------------|-------------------|--------------|-------------------|
| <b>LANDROVER</b> | 06 07 08 09 10 11 | <b>VOLVO</b> | 06 07 08 09 10 11 |
| Freelander-LR2   |                   | V70          |                   |
| <b>VOLVO</b>     | 06 07 08 09 10 11 | XC60         |                   |
| S80              |                   | XC70         |                   |

## CÂBLAGE / GUIDE DE CONNEXIONS

### STEP 1

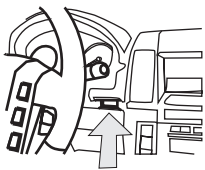

Retirez le barillet d'ignition du tableau de bord (Requière de démonter l'odomètre pour avoir accès au barillet d'ignition)

### STEP 2

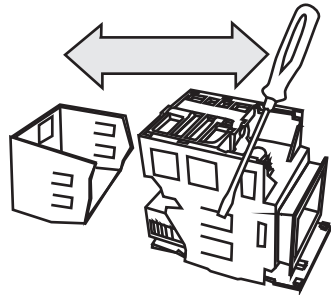

Ouvrir et retirez le module d'ignition à l'aide d'un petit tournevis plat.

### STEP 3

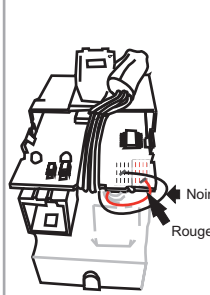

Déssoudez le fil rouge et le fil noir

### STEP 4

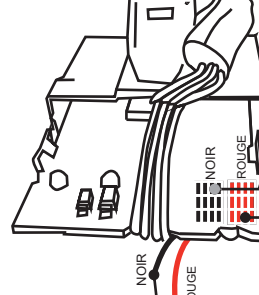

Isoler avec une gaine thermo rétractable (shrink tube)

|        | Fil du INT-LRV |      | Fil du BARILLET D'IGNITION |
|--------|----------------|------|----------------------------|
| Soudez | Brun/Blanc     | à la | borne du fil Noir          |
| Soudez | Gris           | au   | Fil Rouge                  |
| Soudez | Gris/Noir      | au   | Fil Noir                   |
| Soudez | Brun           | à la | borne du fil Rouge         |

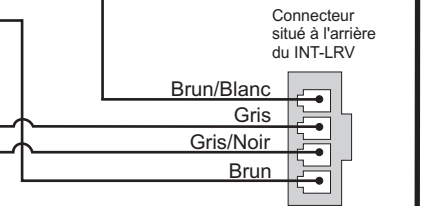

### STEP 5

#### BARILLET DE CLÉ

Faire 3 à 4 tours autour du barillet de clé.

Refermez le module d'ignition

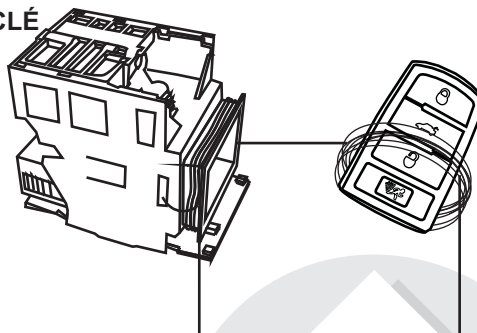
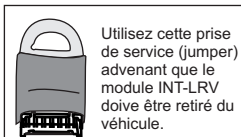

#### TÉLÉCOMMANDE D'ORIGINE

Faire 5 à 10 tours autour de la télécommande d'origine et installez la télécommande dans le tableau de bord. (Dans un endroit inaccessible)

### STEP 6

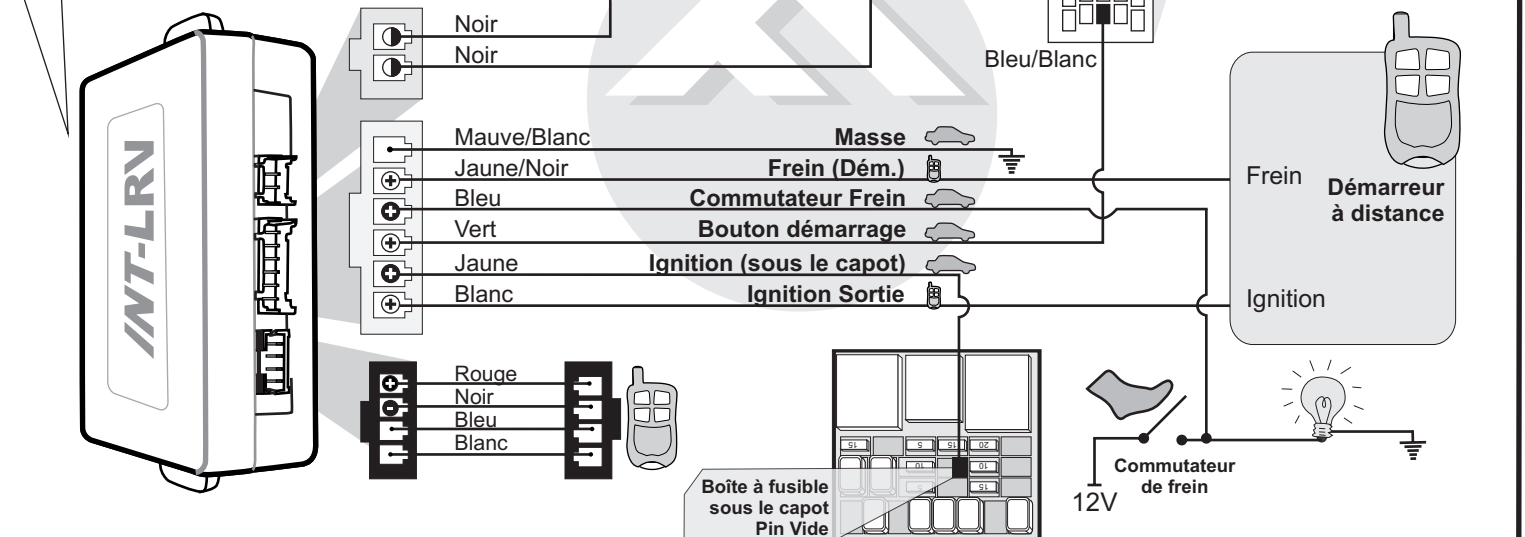

Branchement du filage au démarreur à distance/Alarme

Branchement du filage au véhicule

○ SORTIE

● ENTRÉE

◐ ENTRÉE & SORTIE

## TECHNICAL SUPPORT / INFORMATION

Ni le manufacturier, ni le distributeur ne se considèrent responsables des dommages causés ou ayant pu être causés, indirectement ou directement, par ce module, excepté le remplacement de ce module en cas de défaut de fabrication. Ce module doit être installé par un technicien qualifié. Ce guide d'instruction peut faire l'objet de changement sans préavis. Consultez le [www.ifar.ca](http://www.ifar.ca) pour voir la plus récente version.

**Support Technique:**  
TEL: 514-255-HELP (4357)  
FAX: 514-255-1367  
Web: [www.ifar.ca](http://www.ifar.ca)

