

EVO-CAN

Guide #3025

HONDA / ACURA



HONDA



ACURA

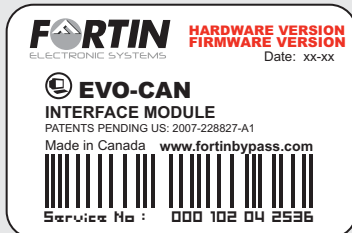
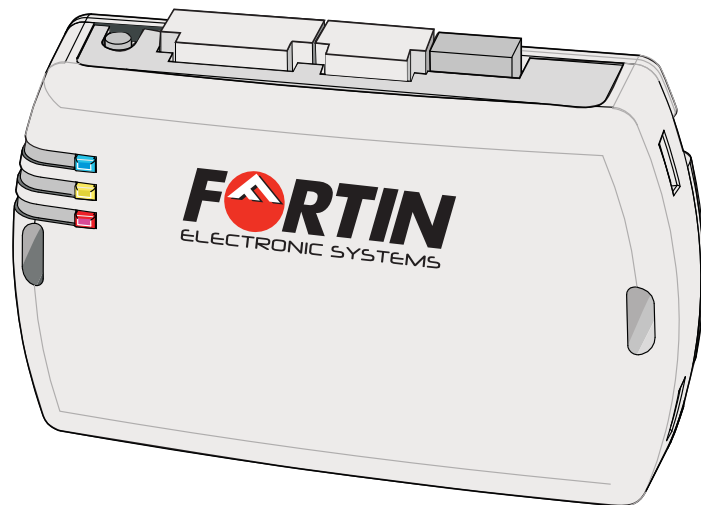

Module label | Étiquette sur le module

Notice: Updated Firmware and Installation Guides

Updated firmware and installation guides are posted on our web site on a regular basis. We recommend that you update this module to the latest firmware and download the latest installation guide(s) prior to the installation of this product.

Des mises à jour du Firmware (microprogramme) et des guides d'installation sont mises en ligne régulièrement. Vérifiez que vous avez bien la dernière version logiciel et le dernier guide d'installation avant l'installation de ce produit.



TECH SUPPORT
 Tél: 514-255-HELP (4357)
 1-877-336-7797



ADDENDUM GUIDE
 Rev : 20120719

www.fortinbypass.com

WEB UPDATE | MISE À JOUR INTERNET



WIRE LEGEND | LEGENDE

Input | *Entrée* Output | *Sortie*

Connection always **required**
Branchement toujours requis

Connection **not required** with Data-link
*Branchement **non requis** avec Data-Link*

Connect to vehicle
Branchement au véhicule

Connect to Remote-Starter/Alarm
Branchement au démarreur à distance/Alarme

Cut | *Couper*

NOTE:

All possible functions are summarized in each configuration, however some functions may not be supported on all vehicles. Refer to the VEHICLE FIT GUIDE to determine the supported functions for a specific vehicle.
Toutes les fonctions possibles sont écrites dans chaque configuration, toutefois elles ne sont pas toutes supportées par tous les véhicules. Voir le GUIDE DES VÉHICULES pour déterminer les fonctions supportées sur chaque véhicule.

DESCRIPTION

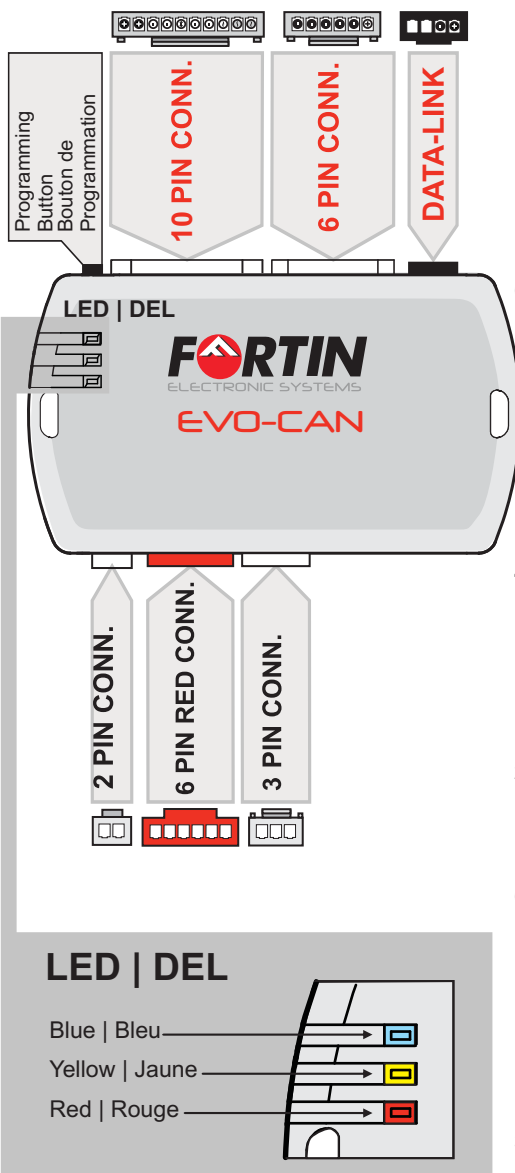

10 PIN CONNECTOR: MAIN HARNESS | HARNAIS PRINCIPAL (WHITE|BLANC)

Yellow Jaune	Ignition
Red/Blue Rouge/Bleu	Start
Green Vert	Door Status Statuts Portes
White Blanc	Trunk Status Statuts Valise
White/Black Blanc/Noir	AUX2 / KEY SENSE
Brown/White Brun/Blanc	Hand Brake Status Frein à Main Signal
Pink/Black Rose/Noir	Hood Status Capot Statuts
Pink Rose	Tachometer
Lt. Blue/Black Bleu Pâle/Noir	DATA 1 See configuration
Lt. Blue Bleu Pâle	DATA 2 See configuration

6 PIN CONNECTOR: MAIN HARNESS | HARNAIS PRINCIPAL (WHITE|BLANC)

Orange/Black Orange/Noir	Foot Brake Status Statuts Frein (ped)
Orange	AUX 1
Purple/White Mauve/Blanc	Unlock/Disarm Déverrouille/Désarme
Purple Mauve	Lock/Arm Verrouille/Arme
Yellow/Black Jaune/Noir	Trunk Release Valise
Dk. Blue Bleu foncé	GWR (Ground While Running)

4 PIN CONNECTOR: DATA-LINK (BLACK | NOIR) SEE PAGE 3 | VOIR PAGE 3

Red Rouge	(+) 12V Battery (+) 12V Batterie
Black Noir	Ground (-) Masse (-)
Blue Bleu	DATA
White Blanc	DATA

2 PIN CONNECTOR: TB CONTROL (WHITE | BLANC)

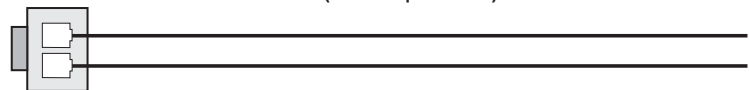

6 PIN CONNECTOR: RELAY | RELAIS (RED | ROUGE)

White/Red Blanc/Rouge	COMM2
White/Blue Blanc/Bleu	NO2
White/Green Blanc/Vert	NC2
Yellow/Red Jaune/Rouge	COMM1
Yellow/Blue Jaune/Bleu	NO1
Yellow/Green Jaune/Vert	NC1

3 PIN CONNECTOR: CAN-BUS (WHITE | BLANC)

Brown Brun	CAN 1 WIRE (SW)
Gray/Black Gris/Noir	CAN LOW
Gray Gris	CAN HIGH

LED | DEL

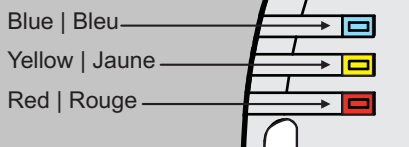

INSTALLATION PROCEDURE

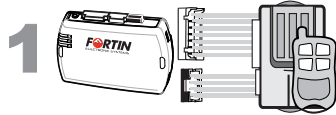

Determine if the remote-starter or alarm system supports 2-way Data-Link.

Déterminez si le démarreur à distance ou système d'alarme est compatible en Data-Link 2-voies.

WITH DATA-LINK AVEC DATA-LINK

In order to utilize this type of connection the remote-starter or alarm-system must be compatible with the **Fortin Data-link protocol**. Consult the installation guide or visit www.fortinbypass.com/datalink/ for more information.

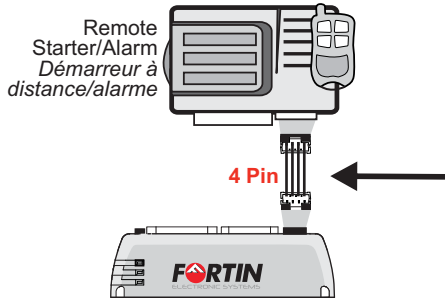

Le démarreur à distance ou le système d'alarme doit être compatible avec le **protocole Data-link Fortin** pour ces branchements. Consultez le guide d'installation du démarreur à distance ou du système d'alarme ou visitez le www.fortinbypass.com/datalink/ pour plus d'informations.

WITH OUT DATA-LINK SANS DATA-LINK

For all other remote-starters or alarm-systems perform the following connections.

Pour tout autres types de démarreurs à distance ou d'alarme, effectuez les branchements suivants.

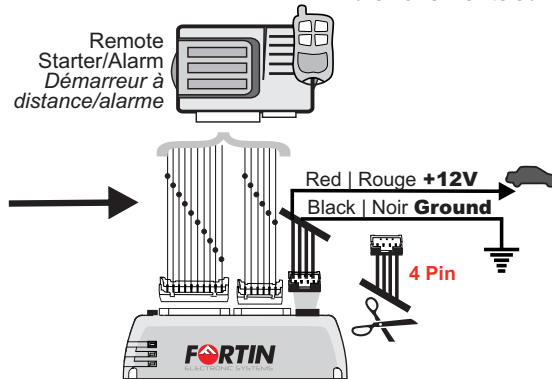

- 1 Cut off one plug of the 4 Pin Data-Link connector
- 2 Connect the Red wire to +12V
- 3 Connect the Black wire to Ground

- 1 Coupez l'extrémité du connecteur 4 pins Data-Link
- 2 Connectez le fil rouge au 12V
- 3 Connectez le fil noir à la masse du véhicule.

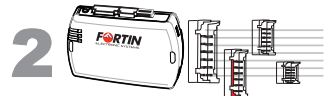

Make the connections:

Faire les branchements:



10 Pin Connector (White):
Make the connections associated with the vehicle from the VEHICLE FIT GUIDE.

10 Pins Connecteur (Blanc):
Effectuez les branchements associés au véhicule dans le GUIDE DES VÉHICULES.



6 Pin Connector (White):
Make the connections (if required)

6 Pins Connecteur (Blanc):
Effectuez les branchements.(Si nécessaire)



3 Pin Connector CAN (White):
Make the connections (if required)

3 Pins Connecteur CAN (Blanc):
Effectuez les branchements.(Si nécessaire)



6 Pin Connector RELAY (Red):
Make the connections (if required)

6 Pins Connecteur RELAI (Rouge):
Effectuez les branchements.(Si nécessaire)



2 Pin Connector (White):
Make the connections (if required)

2 Pins Connecteur (Blanc):
Effectuez les branchements.(Si nécessaire)



PROGRAMMING PROCEDURE

PROCÉDURE DE PROGRAMMATION

Determine the programming procedure required for the vehicle in the VEHICLE FIT GUIDE.

Déterminez le type de programmation selon votre véhicule dans le GUIDE DES VÉHICULES.

Connection number
Numéro de connexion

Vehicle(s) associated with the procedure
Véhicule(s) associé(s) à la configuration

Programming number
Numéro de programmation

CONNECTION #

VEHICLE MAKE MODEL YEAR

PROGRAM: #

VEHICLE FIT GUIDE | GUIDE DES VÉHICULES

VEHICLES VEHICULES		YEARS ANNÉES	Connection	Programming	Functional if equipped Fonctionnelle si le véhicule en est équipé.																										See Legend Below		
					Lock	Unlock	Arm	Disarm	Hatch (open)	Trunk (open)	Sliding Door	Window Roll Down	Gas Door	RAP Disable	Parking Light	Memory Driver	Tachometer	Heated Seats	Heated Mirrors	Rear Defrost	Door Status	Trunk Status	Hood Status	Hand-Brake Status	Foot-Brake Status	Transponder Bypass	PK3, Passlock	Key Control	Activate OEM Remote Start	Push-to-Start Control		Legend	
					A	B	C	D	E	F	G	H	I	J	K	L	M	O	P	Q	R	S	T	U	V	W	X	Y	Z	ZA	ZB		
ACURA																																	
CSX		2006-2011	8	1	•	•	•	•		•							•				•	•		•	•	•							
EL 1.7		2001-2005	2	1																													
MDX		2003-2006	2	1																													
		2007-2012	3	1	•	•	•	•		•											•	•	•	•	•	•							
RDX		2007-2012	8	1	•	•	•	•		•											•	•	•	•	•	•							
		2013	www: 5351		•	•	•	•		•											•	•	•	•	•	•							
RL		1998-2004	5	1																													
		2005-2012	6	1	•	•	•	•		•												•	•	•	•	•	•						
RSX		2002-2006	2	1																													
TL		2004-2008	1	1																													
		2009-2012	4	1	•	•	•	•		•												•	•	•	•	•	•						
	<i>Push-to-Start</i>	2011	9	2	•	•	•	•		•												•	•	•	•	•	•						
TSX		2004-2008	1	1	•	•	•	•		•												•	•	•	•	•	•						
		2009-2012	4	1	•	•	•	•		•																							
HONDA																																	
Accord		2003-2007	1	1	•	•	•	•		•												•	•	•	•	•	•						
		2008-2012	4	1	•	•	•	•		•													•	•	•	•	•	•					
	<i>Accord Hybrid</i>	2005-2007	1	1	•	•	•	•		•													•	•	•	•	•	•					
	<i>Accord Crosstour</i>	2010-2012	4	1	•	•	•	•		•													•	•	•	•	•	•					
Civic or Civic Hybrid		2001-2005	2	1																													
		2006-2011	8	1	•	•	•	•		•												•	•	•	•	•	•						
		2012	7	1	•	•	•	•		•													•	•	•	•	•	•					
CR-V		2002-2006	2	1																													
		2007-2011	8	1	•	•	•	•		•													•	•	•	•	•	•					
		2012	10	1	•	•	•	•		•													•	•	•	•	•	•					
CR-Z Hybrid		2011-2012	8	1			•	•		•													•	•	•	•	•	•					
Element		2003-2010	2	1																													
Fit		2006-2008	2	1																													
		2009-2012	8	1	•	•	•	•		•													•	•	•	•	•	•					
Insight		2010-2012	8	1	•	•	•	•		•													•	•	•	•	•	•					
Odyssey		2005-2010	1	1	•	•	•	•		•													•	•	•	•	•	•					
		2011-2012	4	1	•	•	•	•		•													•	•	•	•	•	•					
Pilot		2005-2008	2	1																													
		2009-2012	4	1	•	•	•	•		•													•	•	•	•	•	•					
Prelude		1997-2001	5	1																													
Ridgeline		2006-2012	1	1	•	•	•	•		•													•	•	•	•	•	•					
S2000		2004-2007	2	1																													

LEGEND | LÉGENDE

- 1 - **TB-GM2*** for transponder bypass pour contournement du transpondeur
- 2 - **TB-KIA1*** for transponder bypass pour contournement du transpondeur
- 3 - **TB-KIA2*** for transponder bypass pour contournement du transpondeur
- 4 - **TB-MITS2*** for transponder bypass pour contournement du transpondeur

- 6 - **INT-BMW1*** for remote car starter | Pour démarreur à distance
- 7 - **TB-SUBARU1 or 2*** for transponder bypass | pour contournement du transpondeur
- 8 - A special diagram is required for Remote car starter : www.fortinbypass.com
Un diagramme spécial est requis pour démarreur à distance : www.fortinbypass.com
- 9 - **INSET*** for remote car starter | Pour démarreur à distance
- 10 - **EVO-CAN** version hardware 3+ required | version du matériel: 3+ requis
- 11 - **EVO-RIDE** for transponder bypass | pour contournement du transpondeur

* Sold separately | Vendu séparément

5 - Heated seats will only turn ON (low power) if the engine temperature is below 0°C (32°F) when remote started.
Les sièges chauffants s'allument à faible intensité SEULEMENT si la température du moteur est sous 0°C

www - Visit www.fortinbypass.com to download an installation guide for this specific vehicle. | Visitez le www.fortinbypass.com pour télécharger un guide d'installation spécifique à ce véhicule.

CONNECTION

CONNECTION 1

PROGRAM: 1

ACURA YEARS	Data Pin 2	CAN SW Pin 4	Security Light Pin 5	Ignition Pin 6	HONDA YEARS	Data Pin 2	CAN SW Pin 4	Security Light Pin 5	Ignition Pin 6
TL	04-06 Red/Blue	Brown/Black	Blue/Orange	Black/Green	Accord	03-07 Red/Blue	Brown/Red	Blue/Orange	Black/Yellow
	07-08 Yellow	Brown/Black	Orange	Black/Green	Hybrid	05 Yellow	Lt Green	Red	Black/Yellow
TSX	04-05 Red/Blue	Brown/Red	Blue/Orange	Black/Yellow	Hybrid	06-07 Yellow	Brown/Red	Red	Black/Yellow
	06-08 Yellow	Brown/Red	Orange	Black/Yellow	Odyssey	05-10 Red/Blue	Green/Red	Blue/Orange	Black/Yellow
					Ridgeline	06-10 Red/Blue	Brown/Black	Blue/Orange	Black/Green

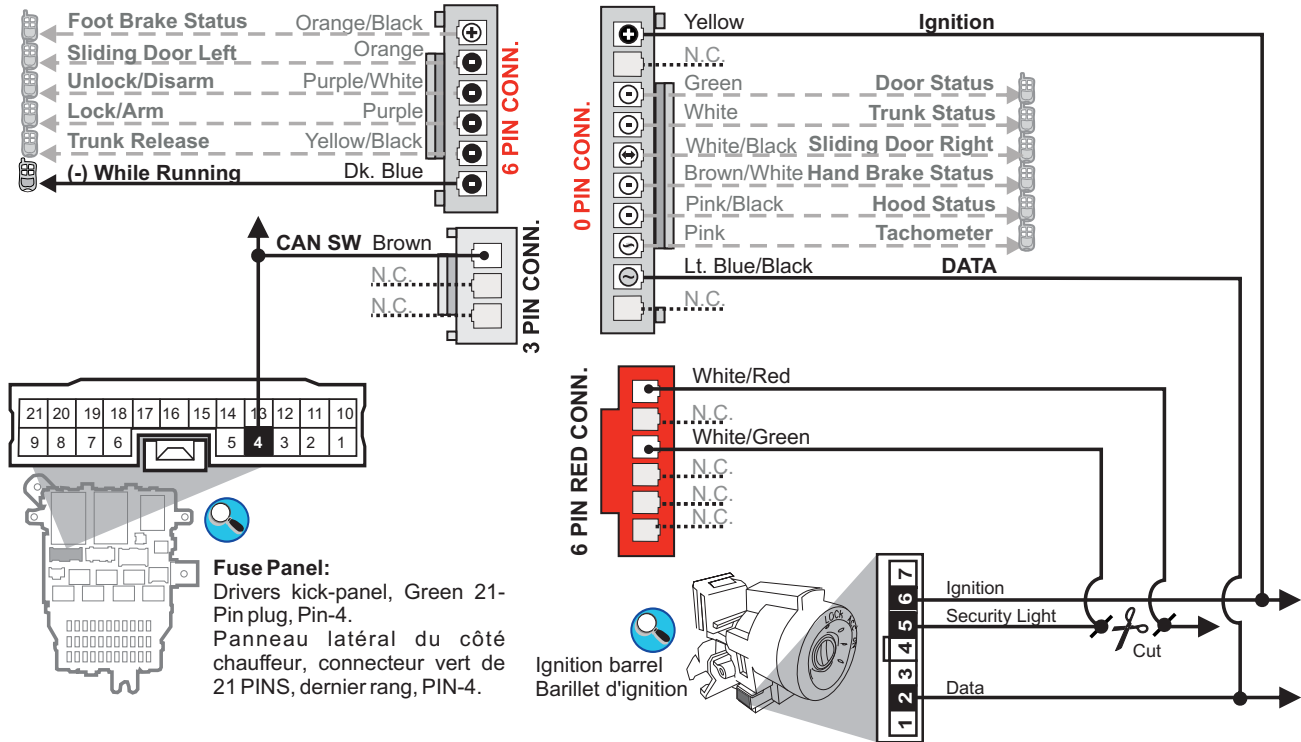

CONNECTION 2

ACURA / HONDA

PROGRAM: 1

ACURA	YEARS	Data Pin 2	Security Light Pin 5	Ignition Pin 6	HONDA	YEARS	Data Pin 2	Security Light Pin 5	Ignition Pin 6
1.7EL	01-05	Red/Blue	Blue/Orange	Yellow/Black	Civic / Hyb	01-05	Red/Blue	Blue/Orange	Yellow/Black
MDX	03-06	Red	Pink	Green/White	CR-V	02-04	White	Blue/Orange	Yellow/Black
RSX	02-03	Red/Blue	Blue/Orange	Yellow/Black		05-06	White	Blue/Orange	Black/Yellow
	04-06	Red/Blue	Blue/Orange	Black/Yellow	Element	03-10	White	Blue/Orange	Black/Yellow
					Fit	06-08	Lt.Green/Black	Red/Black	Black/Yellow
					Pilot	05-08	Red/Green	White/Blue	Red/White
					S-2000	04-07	Red/Blue	Pink	Black/Yellow

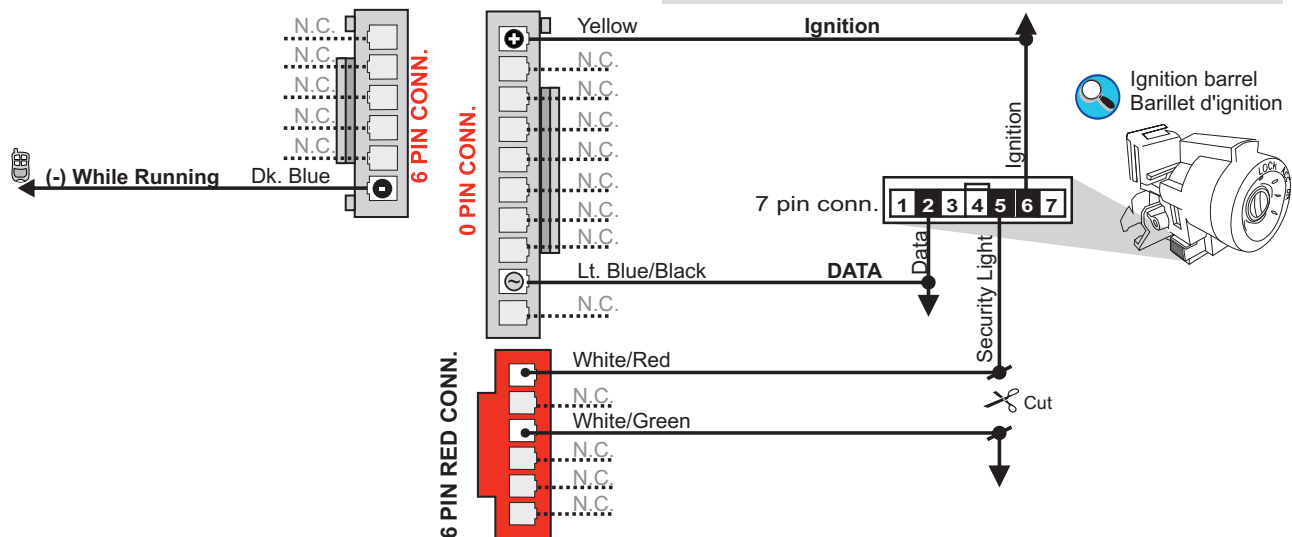

CONNECTION 3

ACURA / HONDA

PROGRAM: 1

ACURA YEARS	Ignition Pin 2	Data Pin 3	CAN SW Pin 4
MDX 07-10	Brown	Light Green	Light Green

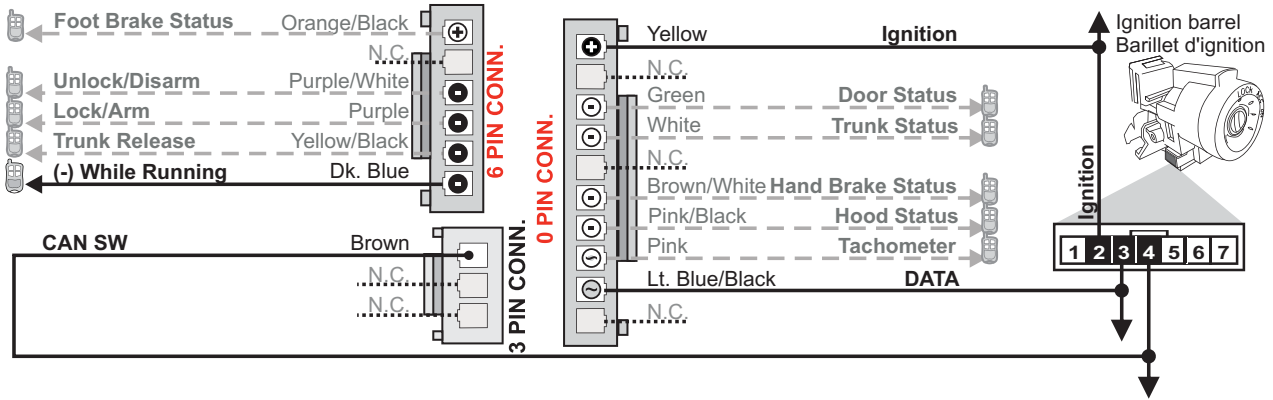

CONNECTION 4

ACURA / HONDA

PROGRAM: 1

ACURA YEARS	Ignition Pin 2	CAN L Pin 3	CAN H Pin 4	Data Pin 6
TL 09-10	Yellow	Blue	Pink	Light Green
TSX 09-10	Yellow	Blue	Pink	Light Green

HONDA YEARS	Ignition Pin 2	CAN L Pin 3	CAN H Pin 4	Data Pin 6
Accord 08-10	Yellow	Blue	Pink	Light Green
Odyssey 11	Yellow	Blue	Pink	Purple
Pilot 09-10	Brown	Lt Green	White	Pink

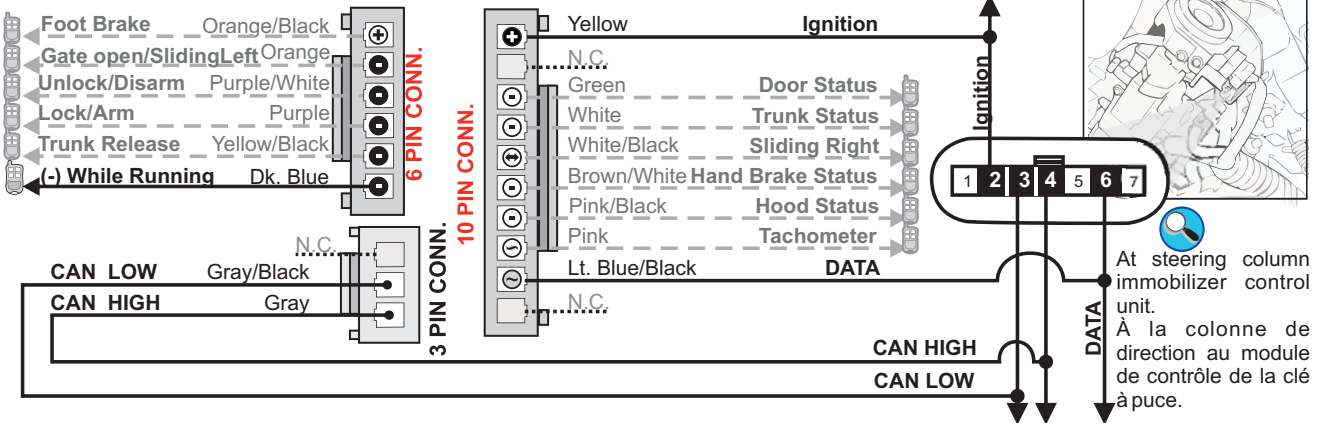

CONNECTION 5

ACURA RL & HONDA PRELUDE

PROGRAM: 1

ACURA YEARS	Start Enable Pin 3	Ignition Pin 4	Data Pin 6
RL 98-04	Pink	Yellow/Black	White

HONDA YEARS	CAN SW Pin 3	Ignition Pin 4	Data Pin 6
Prelude 97	Lt Blue	Black/Yellow	Brown/Yellow
98-01	Lt Blue	Yellow/Black	Brown/Yellow

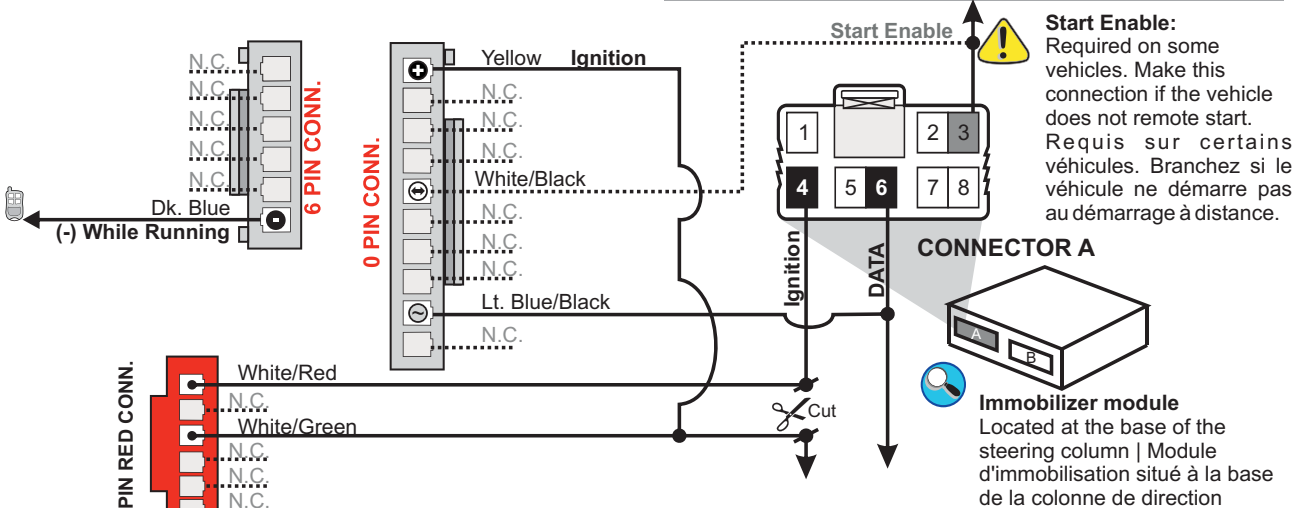

CONNECTION 6

ACURA RL 2005-2010

PROGRAM: 1

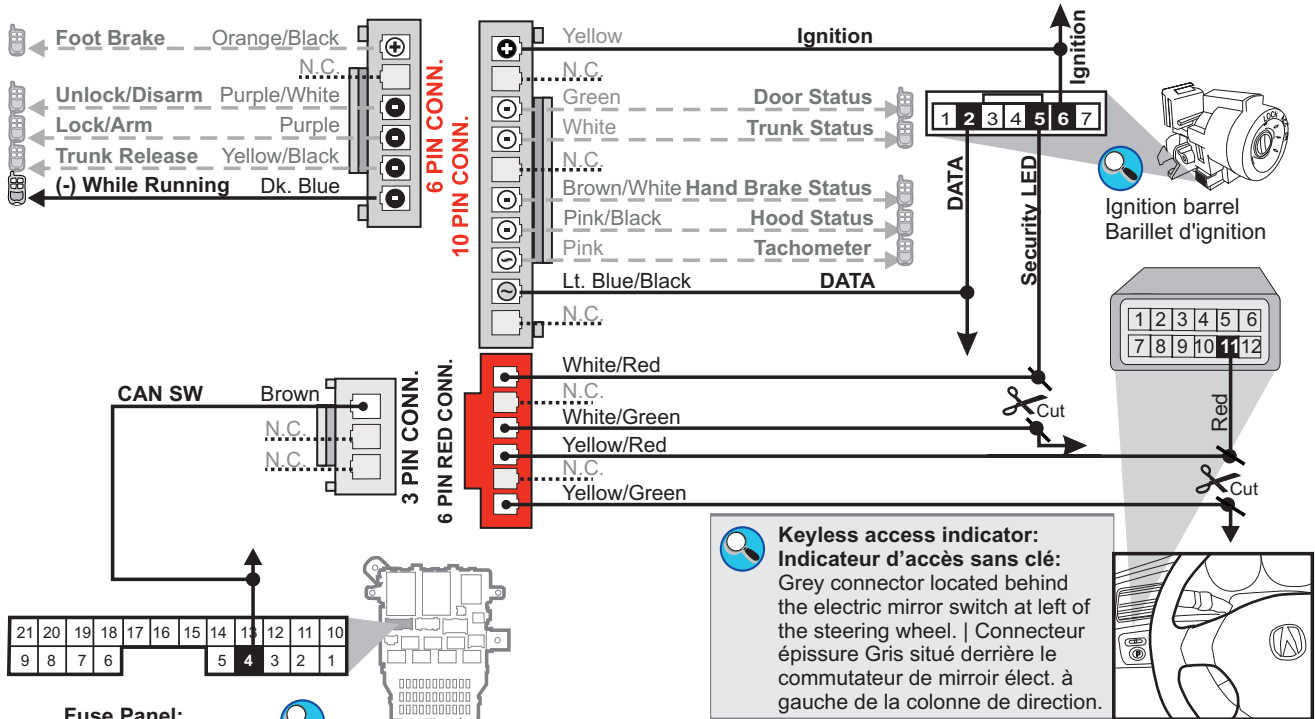

ACURA	YEARS	Data Pin 2	Security Light Pin 5	Ignition Pin 6
RL	05	Lt Green	Blue	Pink
	06	Orange	Red	Pink
	07-10	Orange	Red	Pink

CONNECTION 7

HONDA CIVIC

GO PROGRAM: 1

HONDA	Ignition Pin 2	CAN Low Pin 3	CAN High Pin 4	Data Pin 6	Unlock	Lock
Civic 2012	Yellow	Blue	Pink	Lt.Green	Gray	Lt.Blue

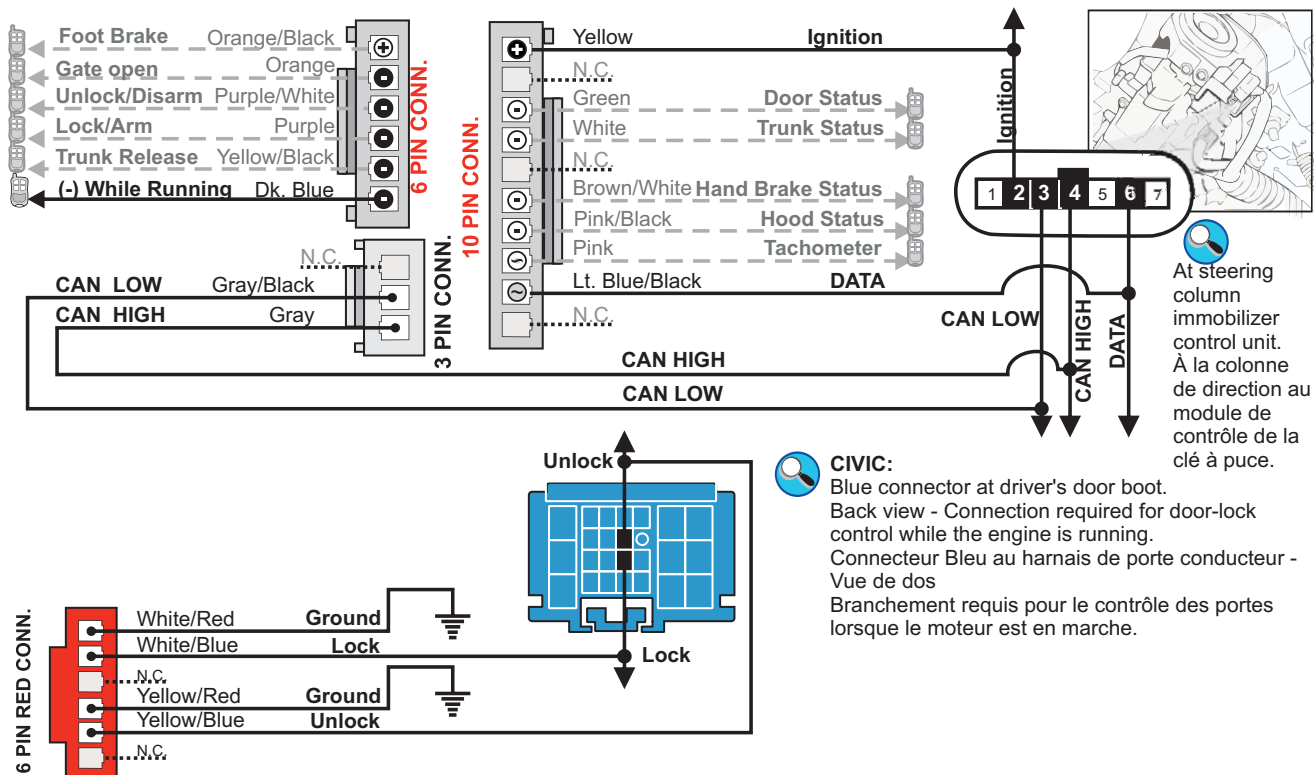

CONNECTION 8

GO PROGRAM: 1

YEARS	Ignition Pin 2	Data Pin 3	CAN SW Pin 4	Lock Analog	Unlock Analog	HONDA YEARS	Ignition Pin 2	Data Pin 3	CAN SW Pin 4	Lock Analog	Unlock Analog
CSX 06-09	Yellow	Lt Green	Pink	Green	Gray	CR-V 07-10	Lt Blue	Green	Pink	Blue	Gray
Civic 06-10	Yellow	Lt Green	Pink	Green	Gray	Fit 09-10	Red	Green	Lt Green	Lt Blue	Gray
Hybrid 06-10	Yellow	Lt Green	Pink	Green	Gray	Insight 10	Red	Lt Green	Green	White	Green

ACURA YEARS	Ignition Pin 2	Data Pin 3	CAN SW Pin 4
RDX 07-10	Yellow	Light Green	Pink

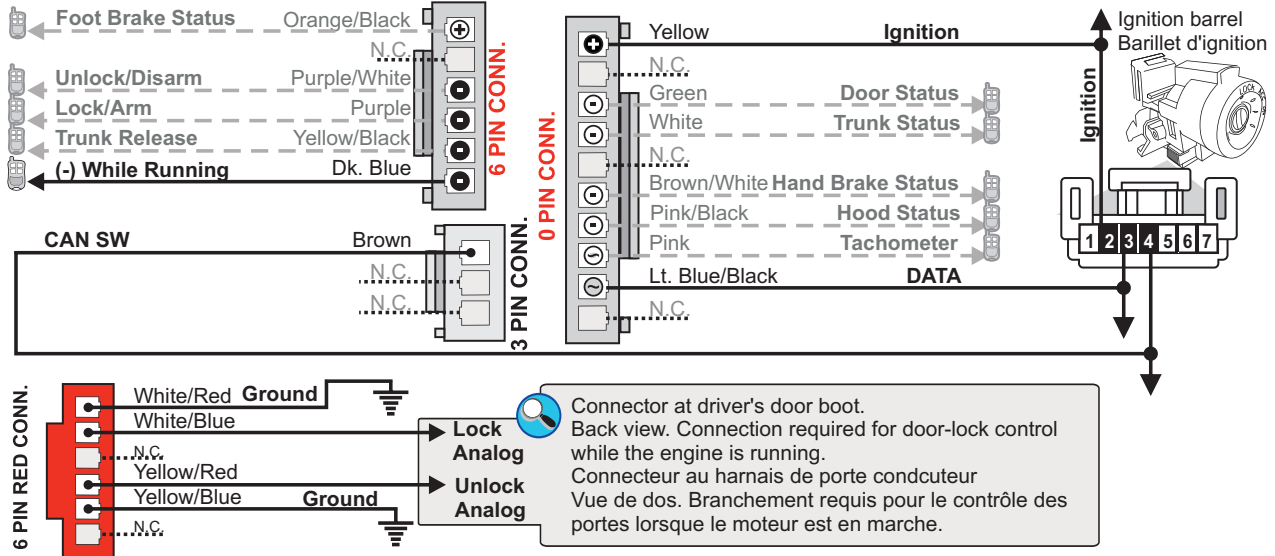

CONNECTION 9

ACURA TL PUSH TO START

GO NEXT PAGE

EVO-CAN Firmware version :2.12 and newer | et plus

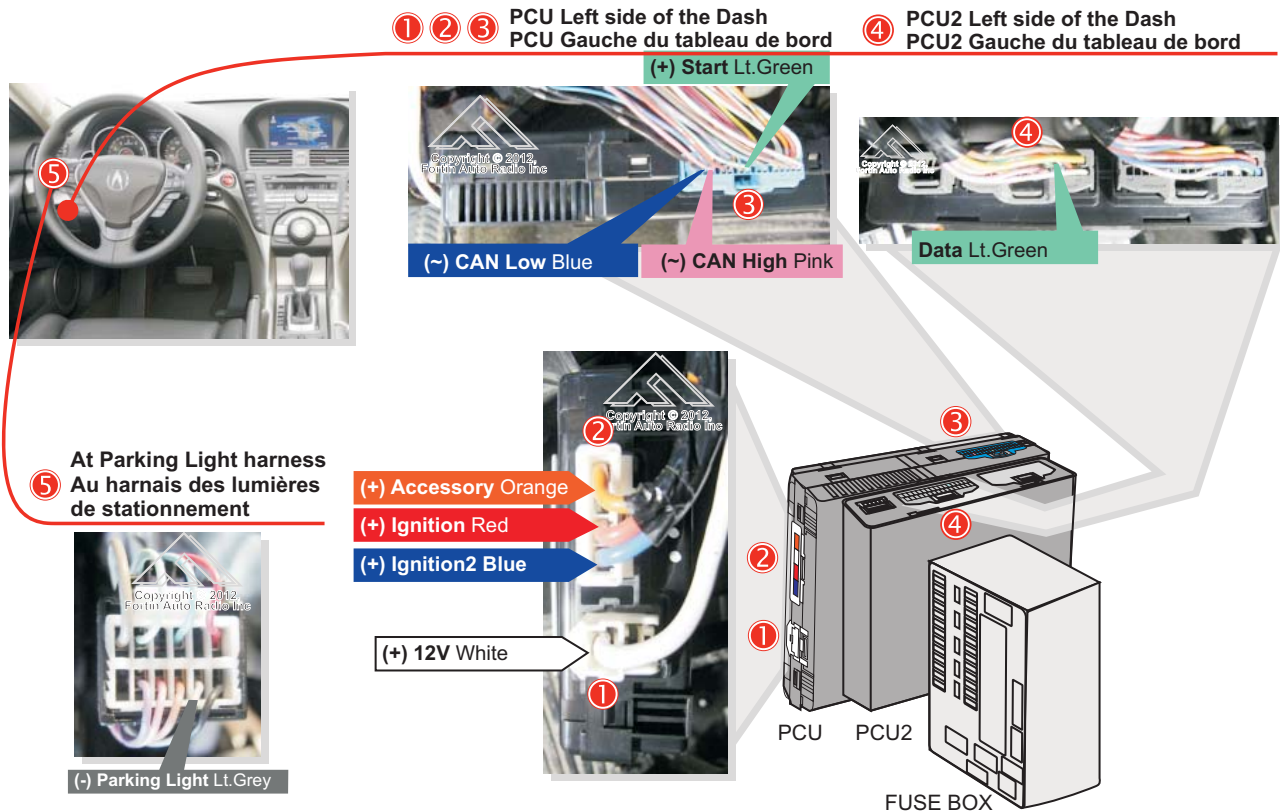

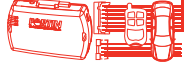

TL CONTINUED | SUITE

GO PROGRAM: 2

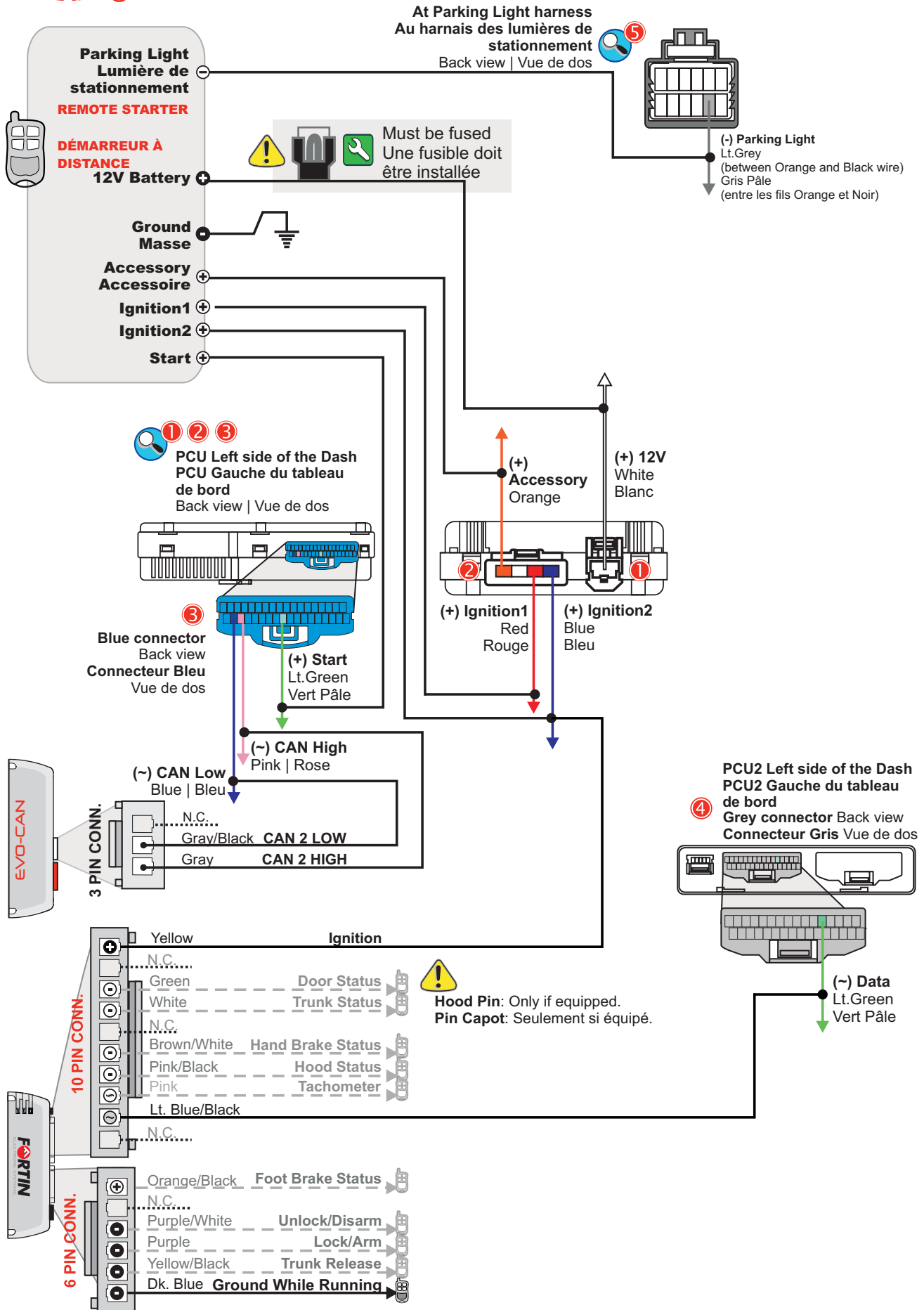

CONNECTION 10

HONDA CRV 2012

GO PROGRAM: 1

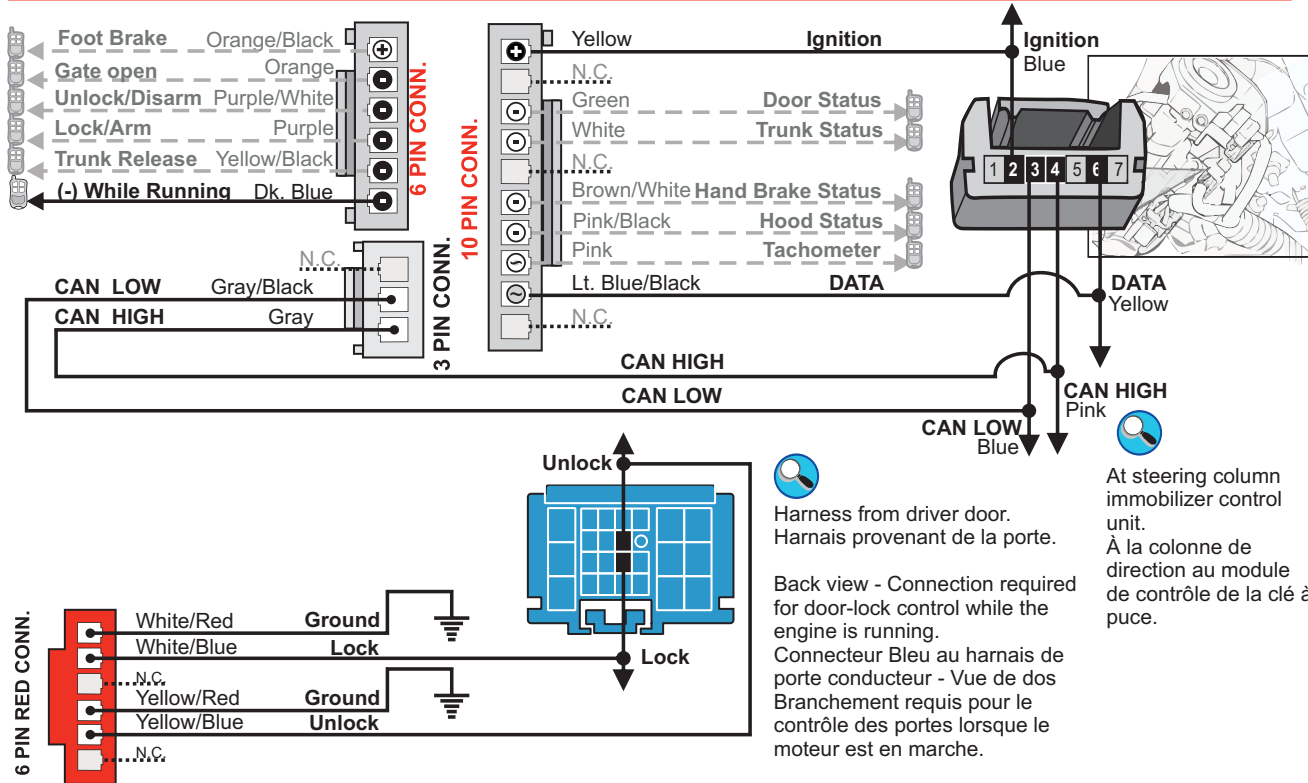

Harness from driver door.
Harnais provenant de la porte.

Back view - Connection required for door-lock control while the engine is running.
Connecteur Bleu au harnais de porte conducteur - Vue de dos
Branchement requis pour le contrôle des portes lorsque le moteur est en marche.



At steering column immobilizer control unit.
À la colonne de direction au module de contrôle de la clé à puce.





1 PROGRAMMING PROCEDURE | PROCÉDURE DE PORGAMMATION

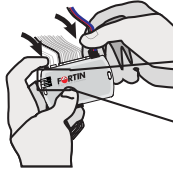
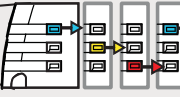
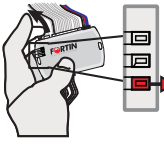
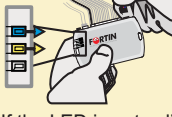
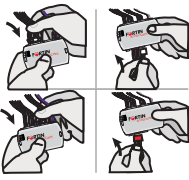

PROGRAM. 1 HONDA / ACURA

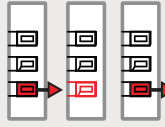
1

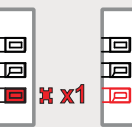
 <p>Press and hold the programming button:</p> <p>Appuyez et maintenir enfoncé le bouton de programmation:</p>	 <p>Insert the 4 Pin (Data-Link) connector.</p> <p>Insérez le connecteur 4 pins (Data-Link).</p>	 <p>The LED's will alternate between BLUE, YELLOW and RED flashes.</p> <p>Les DELS alternent entre un flash BLEU, JAUNE et ROUGE.</p>	 <p>Release the programming button when the LED is RED.</p> <p>Relâchez le bouton de programmation quand la DEL est ROUGE.</p>	 <p>If the LED is not solid RED disconnect the 4 Pin connector (Data-Link) and go back to step 1.</p> <p>Si le DEL n'est pas ROUGE solide débranchez le connecteur 4 pins (Data-Link) et allez à l'étape 1.</p>	 <p>Insert the remaining required connectors: 10 pin (White), 2 pin (White), 6 pin (White), 6 pin (Red), 3 pin (White).</p> <p>Insérez les connecteurs requis restants: 10 pins (Blanc), 2 pins (Blanc), 6 pins (Blanc), 6 pins (Rouge), 3 pins (Blanc).</p>
---	---	--	---	--	---

2 **3** **4**

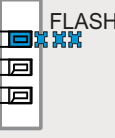
 <p>Press and release the programming button once (1x).</p> <p>Appuyez et relâchez 1 fois le bouton de programmation.</p>	 <p>The RED LED will turn OFF and then back ON</p> <p>La DEL ROUGE s'éteint et se rallume.</p>	 <p>Press and release the programming button once (1x).</p> <p>Appuyez et relâchez 1 fois le bouton de programmation.</p>	 <p>The RED LED will flash 1 once each second.</p> <p>La DEL ROUGE clignote 1 fois chaque seconde.</p>	 <p>Turn the Ignition to the ON/RUN position.</p> <p>Tournez la clef en position ignition (ON).</p>	 <p>The RED LED will flash rapidly 10x times. Key bypass programmed.</p> <p>La DEL ROUGE clignotera 10x fois rapidement. Contournement de clé programmé.</p>
--	---	--	---	---	---

 <p>The BLUE LED will flash rapidly. CAN-Bus programmed.</p> <p>La DEL BLEU clignotera rapidement: Réseau CAN programmé.</p>	 <p>Turn the Ignition to the OFF position.</p> <p>Tournez la clef à OFF.</p>	 <p>The module is now programmed.</p> <p>Le module est programmé.</p>
---	---	--

Use the remote of the remote starter or security system to test all of the supported features to ensure proper programming. Testez toutes les fonctions supportées sur le véhicule avec la télécommande du démarreur à distance ou du système de sécurité.

PROGRAM. 2

ACURA TL

<p>1</p> <p>Press and hold the programming button:</p> <p>Appuyez et maintenir enfoncé le bouton de programmation:</p>	<p>Insert the 4 Pin (Data-Link) connector.</p> <p>Insérez le connecteur 4 pins (Data-Link).</p>	<p>The LED will alternate between BLUE, YELLOW and RED flashes. Les DELS alternent entre un flash BLEU, JAUNE et ROUGE.</p>	<p>Release the programming button when the LED is RED</p> <p>Relâchez le bouton de programmation quand la DEL est ROUGE</p>	<p>If the LED is not solid RED disconnect the 4 Pin connector (Data-Link) and go back to beginning of step 1. Si le DEL n'est pas ROUGE solide débranchez le connecteur 4 pins (Data-Link) et allez au début de l'étape 1.</p>	<p>2</p> <p>Insert the remaining required connectors: 10 pin (White), 2 pin (White), 6 pin (White), 6 pin (Red), 3 pin (White).</p> <p>Insérez les connecteurs requis restants: 10 pins (Blanc), 2 pins (Blanc), 6 pins (Blanc), 6 pins (Rouge), 3 pins (Blanc).</p>
<p>3</p> <p>Press the programming button once (1x).</p> <p>Appuyez et relâchez 1 fois le bouton de programmation.</p>	<p>The RED LED will turn OFF and turn back ON.</p> <p>La DEL ROUGE s'éteint et se rallume.</p>	<p>4</p> <p>Press the programming button once (1x).</p> <p>Appuyez et relâchez 1 fois le bouton de programmation.</p>	<p>The RED LED will flash 1 once every second.</p> <p>La DEL ROUGE clignote 1 fois chaque seconde.</p>	<p>Press the Push-to-Start button twice to turn on the ignition. (Do not press the brake pedal)</p> <p>Appuyez 2 fois sur le bouton démarrage (Push-to-Start) pour allumer l'ignition. (Ne pas appuyer sur la pédale de frein)</p>	
<p>The Red LED will flash 10 times, Key bypass : programming complete. La DEL Rouge clignote 10 fois : Contournement de clé: programmation complété.</p>	<p>Once the Blue LED starts to flash rapidly: Lorsque la DEL Bleu clignote rapidement:</p>	<p>press the Push-to-Start button once to shut off the ignition.</p> <p>appuyez une fois sur le bouton démarrage (Push-to-Start) pour éteindre l'ignition.</p>	<p>The LED will turn off. Le DEL s'éteint.</p>	<p>The module is now programmed. Le module est programmé.</p> <p>Use the remote of the remote starter or security system to test all of the supported features to ensure proper programming. Testez toutes les fonctions supportées sur le véhicule avec la télécommande du démarreur à distance ou du système de sécurité.</p>	

REMOTE STARTER FUNCTIONALITY | FONCTIONNALITÉS DU DÉMARREUR À DISTANCE

<p>All doors must be closed. Toutes les portes doivent être fermées</p>	<p>Remote start the vehicle. Démarrez à distance.</p>	<p>The module will shut down the vehicle as soon as the drivers door is opened. Lors de l'ouverture de la porte conducteur le véhicule s'éteindra par sécurité.</p>	<p>Enter the vehicle with the Smart-Key. Entrez dans le véhicule avec la clé intelligente (Smart-Key) sur vous</p>	<p>Press the brake pedal. Appuyez sur la pédale de frein</p>	<p>Press the Push-to-Start button once. Appuyez 1 fois sur le bouton démarrage (Push-to-Start).</p>	<p>The vehicle can now be put in to gear and driven. Vous êtes maintenant prêt à embrayer et prendre la route.</p>
---	---	---	--	--	---	--

EVO-CAN

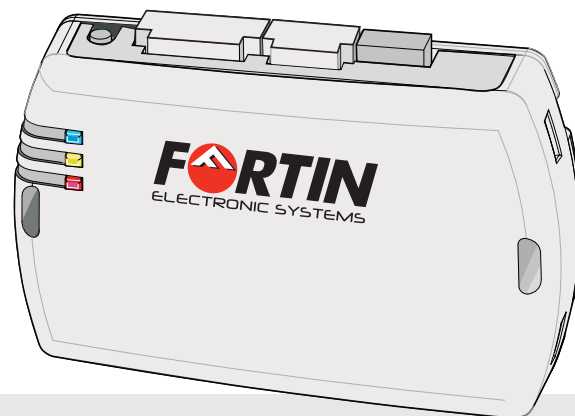

Module label | Étiquette sur le module

Notice: Updated Firmware and Installation Guides

Updated firmware and installation guides are posted on our web site on a regular basis. We recommend that you update this module to the latest firmware and download the latest installation guide(s) prior to the installation of this product.

Des mises à jour du Firmware (microprogramme) et des guides d'installation sont mises en ligne régulièrement. Vérifiez que vous avez bien la dernière version logiciel et le dernier guide d'installation avant l'installation de ce produit.

WARNING / TECH SUPPORT / MISE EN GARDE / SUPPORT TECHNIQUE

The information on this sheet is provided on an (as is) basis with no representation or warranty of accuracy whatsoever. It is the sole responsibility of the installer to check and verify any circuit before connecting to it. Only a computer safe logic probe or digital multimeter should be used. FORTIN ELECTRONIC SYSTEMS assumes absolutely no liability or responsibility whatsoever pertaining to the accuracy or currency of the information supplied. The installation in every case is the sole responsibility of the installer performing the work and FORTIN ELECTRONIC SYSTEMS assumes no liability or responsibility whatsoever resulting from any type of installation, whether performed properly, improperly or any other way. Neither the manufacturer or distributor of this module is responsible of damages of any kind indirectly or directly caused by this module, except for the replacement of this module in case of manufacturing defects. This module must be installed by qualified technician. The information supplied is a guide only. This instruction guide may change without notice. **Visit www.fortinbypass.com to get the latest version.**

L'information de ce guide est fournie sur la base de représentation (telle quelle) sans aucune garantie de précision et d'exactitude. Il est de la seule responsabilité de l'installateur de vérifier tous les fils et circuit avant défectuer les connections. Seule une sonde logique ou un multimètre digital doivent être utilisés. FORTIN SYSTÈMES ÉLECTRONIQUES n'assume aucune responsabilité de l'exactitude de l'information fournie. L'installation (dans chaque cas) est la responsabilité de l'installateur effectuant le travail. FORTIN SYSTÈMES ÉLECTRONIQUES n'assume aucune responsabilité suite à l'installation, que celle-ci soit bonne ou mauvaise ou de n'importe autre type. Ni le fabricant, ni le distributeur ne se considèrent responsables des dommages causés ou ayant pu être causés, indirectement ou directement, par ce module, excepté le remplacement de ce module en cas de défectuosité de fabrication. Ce module doit être installé par un technicien qualifié. L'information fournie dans ce guide est une suggestion. Ce guide d'instruction peut faire l'objet de changement sans préavis. **Consultez le www.fortinbypass.com pour voir la plus récente version.**

Copyright © 2006-2011, FORTIN AUTO RADIO INC ALL RIGHTS RESERVED **PATENT PENDING**



TECH SUPPORT

Tél: 514-255-HELP (4357)
1-877-336-7797



ADDENDUM GUIDE

www.fortinbypass.com
WEB UPDATE | MISE À JOUR INTERNET

