

**REGULAR INSTALLATION
INSTALLATION RÉGULIÈRE**

 ADDENDUM - SUGGESTED WIRING CONFIGURATION
ADDENDA - SCHÉMA DE BRANCHEMENT SUGGÉRÉ

VEHICLE VEHICULES	YEARS ANNÉES	Vehicle functions supported in this diagram (functional if equipped) Fonctions du véhicule supportées dans ce diagramme (fonctionnelles si équipé)														
		Immobilizer bypass	Lock	Unlock	Arm	Disarm	Parking Lights	RAP control	Tachometer	Door Status	Trunk Status	Hood Status	Hand-Brake Status	Foot-Brake Status	Push-to-Start Control	OEM Remote Monitoring
INFINITI																
Q50	Hybrid Push-to-start	2014-2016	•	•	•	•	•	•	•	•	•	•	•	•	•	•

	HARDWARE VERSION VERSION MATÉRIELLE	FIRMWARE VERSION VERSION LOGICIELLE	This manual may change without notice. www.fortinbypass.com for latest version. Ce Guide peut faire l'objet de changement sans préavis. www.fortinbypass.com pour la récente version.
	MINIMUM 6	72.[20] <small>NISSAN/INFINITI MINIMUM</small>	

	Program bypass option: Programmez l'option du contournement:	UNIT OPTION OPTION UNITE	DESCRIPTION
		C1	OEM Remote status (Lock/Unlock) monitoring Suivi des status (Verrouillage/Déverrouil- lage) de la télécommande d'origine
	Program bypass option (Vehicle hybrid only): Programmez l'option du contournement (vehicule hybride seulement):	UNIT OPTION OPTION UNITE	DESCRIPTION
		D4	Hybrid mode (Vehicle hybrid only) Mode hybride (vehicule hybride seulement)

Parts required (Not included)

 1X 15 Amp Fuse
1X 1 Amp Diode

Pièce(s) require(s) (Non include(s))

 1X fusible 15 Amp
1X Diode 1 Amp

DESCRIPTION | DESCRIPTION

⑥ Back of glove box
Derrière la boîte à gants

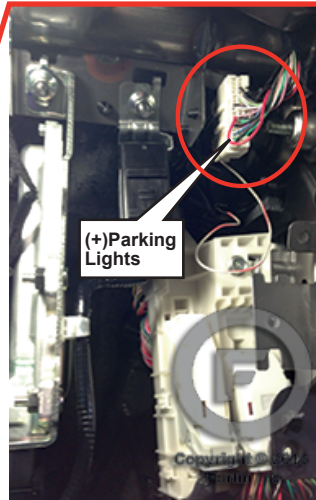

(+)Parking Lights



BCM located in passenger kick panel | BCM Situé dans le panneau latéral côté passager

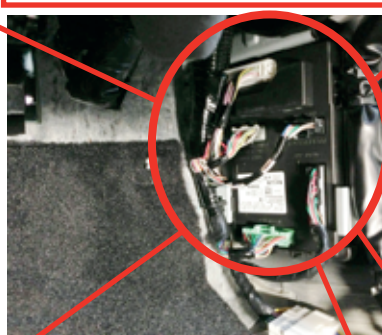

⑤ BCM Grey 24-Pin connector
BCM Connecteur Gris de 24-pins

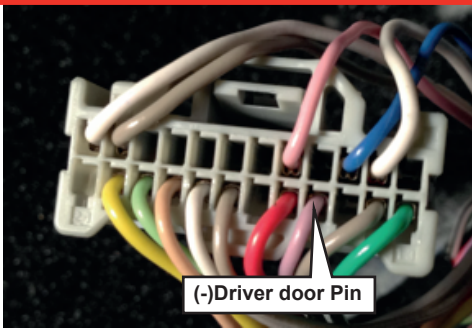

(-)Driver door Pin

② BCM Black 40-Pin connector
BCM Connecteur Noir de 40-pins

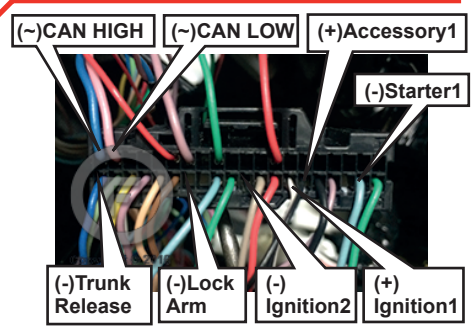

(-)CAN HIGH (-)CAN LOW (+)Accessory1 (-)Starter1 (-)Trunk Release (-)Lock Arm (-) Ignition2 (+) Ignition1

④ BCM Green 40-Pin connector
BCM Connecteur Vert de 40-pins

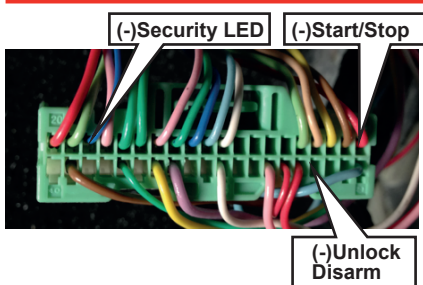

(-)Security LED (-)Start/Stop (-)Unlock Disarm

① BCM White 15-Pin connector
BCM Connecteur Blanc de 15-pins

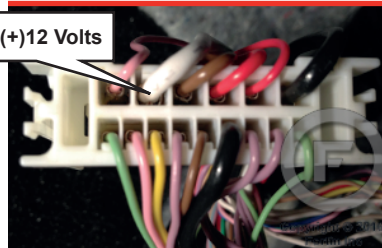

(+)12 Volts

③ BCM Black 24-Pin connector
BCM Connecteur Noir de 24-pins

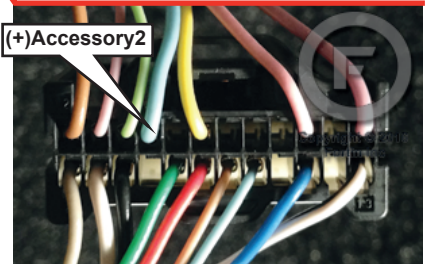

(+)Accessory2

WIRING CONNECTION | GUIDE DE BRANCHEMENTS

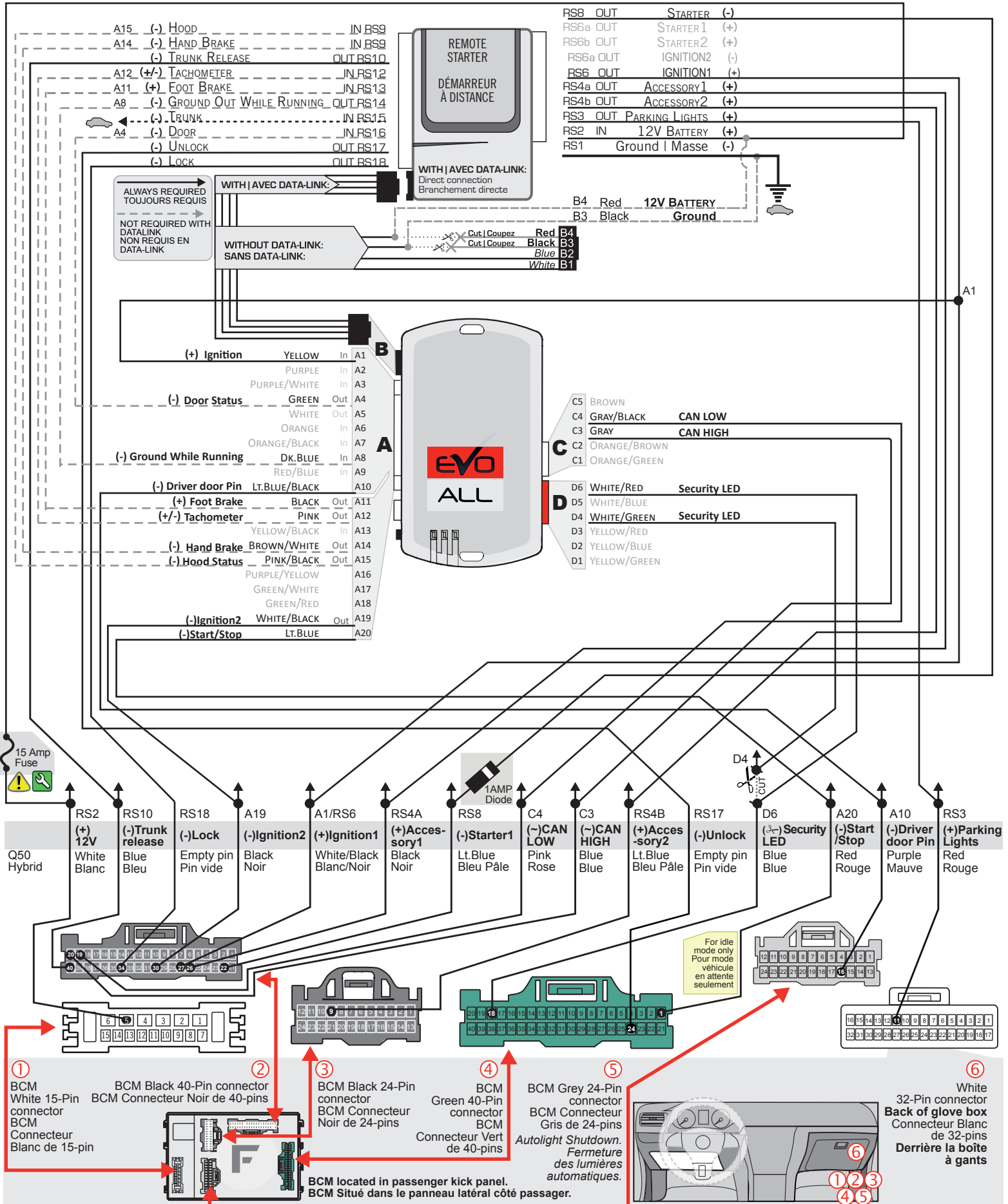

PROGRAMMING PROCEDURE | PROCÉDURE DE PROGRAMMATION

1

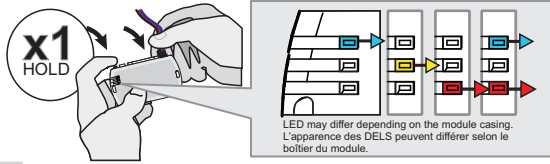

Press and hold the programming button:
Connect the 4-PIN Data-link harness (Black connector).

↳ The Blue, Red, Yellow and Blue & Red LEDs will alternatively illuminate.

Appuyez et maintenez enfoncé le bouton de programmation:
Branchez le harnais Data-Link à 4-Broches (connecteur Noir)

↳ Les DELs Bleue, Rouge, Jaune et Bleue & Rouge s'allumeront alternativement.

2

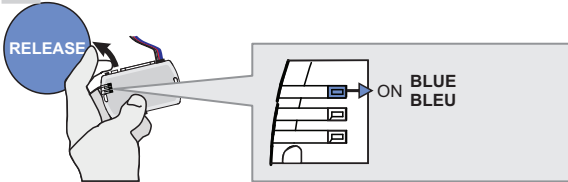

Release the programming button when the LED is BLUE.

Relâchez le bouton de programmation quand la DEL est BLEU.

If the LED is not solid BLUE disconnect the 4-Pin connector (Data-Link) and go back to step 1.

Si le DEL n'est pas BLEU débranchez le connecteur 4 pins (Data-Link) et allez au début de l'étape 1.

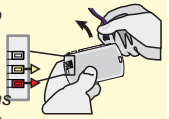

3

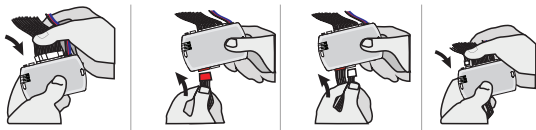

Insert the required remaining connectors.

Insérez les connecteurs requis restants.

4

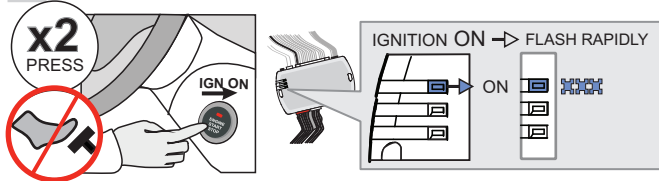

Do not press the brake pedal.
Press the Push-to-Start button twice to turn on the ignition.
↳ The BLUE LED will flash rapidly.

Ne pas appuyer sur la pédale de frein.
Appuyez 2 fois sur le bouton démarrage (Push-to-Start) pour allumer l'ignition.
↳ La DEL BLEUE clignotera rapidement.

5

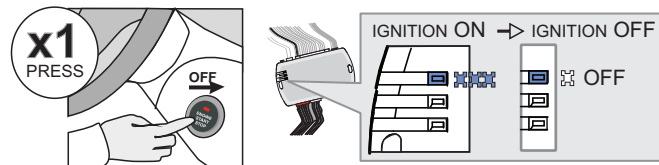

Press the Push-to-Start button once to turn off the ignition.
↳ The BLUE LED will turn off.





Appuyez 1 fois sur le bouton démarrage (Push-to-Start) pour éteindre l'ignition.
↳ La DEL BLEUE s'éteint.

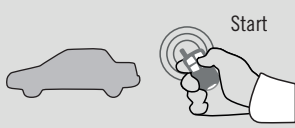

The module is now programmed.

Le module est programmé.

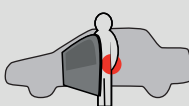
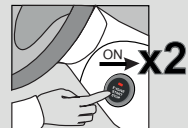
REMOTE STARTER FUNCTIONALITY | FONCTIONNALITÉS DU DÉMARREUR À DISTANCE

 <p>All doors must be closed. Toutes les portes doivent être fermées</p> <p>Remote start the vehicle. Démarrez à distance.</p>	 <p>Unlock the doors with either:</p> <ul style="list-style-type: none"> • The OEM remote • The remote-starter remote <p>• Or the proximity remote</p> <p>Déverrouillez les portes avec soit:</p> <ul style="list-style-type: none"> • la télécommande d'origine • la télécommande du démarreur à distance • ou la télécommande de proximité. 	 <p>Enter the vehicle with the SMART-KEY.</p> <p>Entrez dans le véhicule avec la clé intelligente (SMART-Key) sur vous</p>	 <p>Press the Push-to-Start button twice to turn ON the ignition.</p> <p>Appuyez 2 fois sur le bouton démarrage (Push-to-Start) pour allumer l'ignition.</p>	 <p><i>The vehicle can now be put in to gear and driven.</i></p> <p><i>Vous êtes maintenant prêt à embrayer et prendre la route.</i></p>
---	---	---	---	---

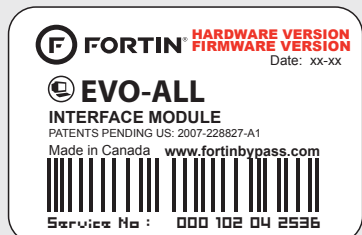

Module label | Étiquette sur le module

Notice: Updated Firmware and Installation Guides

Updated firmware and installation guides are posted on our web site on a regular basis. We recommend that you update this module to the latest firmware and download the latest installation guide(s) prior to the installation of this product.

Notice: Mise à jour microprogramme et Guides d'installations

Des mises à jour du Firmware (microprogramme) et des guides d'installation sont mis en ligne régulièrement. Vérifiez que vous avez bien la dernière version logiciel et le dernier guide d'installation avant l'installation de ce produit.

WARNING

The information on this sheet is provided on an (as is) basis with no representation or warranty of accuracy whatsoever. It is the sole responsibility of the installer to check and verify any circuit before connecting to it. Only a computer safe logic probe or digital multimeter should be used. FORTIN ELECTRONIC SYSTEMS assumes absolutely no liability or responsibility whatsoever pertaining to the accuracy or currency of the information supplied. The installation in every case is the sole responsibility of the installer performing the work and FORTIN ELECTRONIC SYSTEMS assumes no liability or responsibility whatsoever resulting from any type of installation, whether performed properly, improperly or any other way. Neither the manufacturer or distributor of this module is responsible of damages of any kind indirectly or directly caused by this module, except for the replacement of this module in case of manufacturing defects. This module must be installed by qualified technician. The information supplied is a guide only. This instruction guide may change without notice. Visit www.fortinbypass.com to get the latest version.

MISE EN GARDE

L'information de ce guide est fournie sur la base de représentation (telle quelle) sans aucune garantie de précision et d'exactitude. Il est de la seule responsabilité de l'installateur de vérifier tous les fils et circuits avant d'effectuer les connexions. Seuls une sonde logique ou un multimètre digital doivent être utilisés. FORTIN SYSTÈMES ÉLECTRONIQUES n'assume aucune responsabilité de l'exactitude de l'information fournie. L'installation (dans chaque cas) est la responsabilité de l'installateur effectuant le travail. FORTIN SYSTÈMES ÉLECTRONIQUES n'assume aucune responsabilité suite à l'installation, que celle-ci soit bonne, mauvaise ou de n'importe autre type. Ni le manufacturier, ni le distributeur ne se considèrent responsables des dommages causés ou ayant pu être causés, indirectement ou directement, par ce module, excepté le remplacement de ce module en cas de défectuosité de fabrication. Ce module doit être installé par un technicien qualifié. L'information fournie dans ce guide est une suggestion. Ce guide d'instruction peut faire l'objet de changement sans préavis. Consultez le www.fortinbypass.com pour voir la plus récente version.

Copyright © 2006-2014, FORTIN AUTO RADIO INC ALL RIGHTS RESERVED PATENT PENDING



TECH SUPPORT

Tél: 514-255-HELP (4357)
1-877-336-7797



ADDENDUM GUIDE

www.fortinbypass.com

WEB UPDATE | MISE À JOUR INTERNET

