

**THAR-VW2 INSTALLATION / TB-VW  
INSTALLATION THAR-VW2 / TB-VW**

ADDENDUM - SUGGESTED WIRING CONFIGURATION  
ADDENDA - SCHÉMA DE BRANCHEMENT SUGGÉRÉ



VEHICLE  
VEHICULES

YEARS  
ANNÉES

Vehicle functions supported in this diagram (functional if equipped) | Fonctions du véhicule supportées dans ce diagramme (fonctionnelles si équipé)

**VOLKSWAGEN**

GTI	2011-2014	•	•	•	•	•	•	•	•	•	•	•	•	•	•	•	•	•
-----	-----------	---	---	---	---	---	---	---	---	---	---	---	---	---	---	---	---	---

	<b>HARDWARE VERSION</b> VERSION MATÉRIELLE  <b>3</b> MINIMUM	<b>REMOTE STARTER</b> FIRMWARE VERSION VERSION LOGICIELLE DU DÉMARREUR À DISTANCE  <b>1.[20]</b> MINIMUM	<b>BYPASS</b> FIRMWARE VERSION  <b>75.[25]</b> VW MINIMUM	This manual may change without notice. www.fortinbypass.com for latest version. Ce Guide peut faire l'objet de changement sans préavis. www.fortinbypass.com pour la récente version.
--	--------------------------------------------------------------------------	----------------------------------------------------------------------------------------------------------------------------	-----------------------------------------------------------------------	---------------------------------------------------------------------------------------------------------------------------------------------------------------------------------------------------

	<b>Program bypass option:</b> Programmez l'option du contournement:	<b>UNIT OPTION</b> OPTION UNITE  <b>C1</b>	<b>DESCRIPTION</b> OEM Remote status (Lock/Unlock) monitoring Suivi des status (Verrouillage/Déverrouil- lage) de la télécommande d'origine
--	------------------------------------------------------------------------	-----------------------------------------------------	---------------------------------------------------------------------------------------------------------------------------------------------------------

	<b>Program bypass option</b> <b>(If equipped with OEM alarm):</b> Programmez l'option du contournement <b>(Si équipé d'une alarme d'origine):</b>	<b>UNIT OPTION</b> OPTION UNITE  <b>D2</b>	<b>DESCRIPTION</b> Unlock before / Lock after (Disarm OEM alarm) Déverrouille avant / Verrouille après (Désarme l'alarme d'origine)
--	------------------------------------------------------------------------------------------------------------------------------------------------------------	-----------------------------------------------------	-------------------------------------------------------------------------------------------------------------------------------------------------

	<b>Program remote starter option for R.S.</b> <b>OEM REMOTE STAND ALONE:</b> Programmez l'option démarrreur à distance pour <b>TÉLÉCOMMANDE D'ORIGINE STAND ALONE:</b>	<b>FUNCTION</b> FONCTION  <b>38</b>	<b>MODE</b>  <b>2</b>	<b>DESCRIPTION</b> Enable Press 3x Lock to remote start with the OEM remote.  Activé Appuyez x3 sur Verrouille de la télécommande d'origine pour démarrer à distance le véhicule.
--	----------------------------------------------------------------------------------------------------------------------------------------------------------------------------------------------------	----------------------------------------------	-----------------------------	-----------------------------------------------------------------------------------------------------------------------------------------------------------------------------------------------------



**Parts required (Not included)**

1x TB-VW  
1x THAR-VW2

**FLASH LINK MANAGER**  
Software version 3.63 and more

**Pièce(s) requise(s) (Non incluse(s))**

1x TB-VW  
1x THAR-VW2

**FLASH LINK MANAGER**  
Version logicielle 3.63 et plus



**FLASH LINK UPDATER 2**

1X

Microsoft Windows Computer &  
Internet connection

**FLASH LINK UPDATER 2**

Ordinateur Microsoft Windows &  
connection Internet



DESCRIPTION | DESCRIPTION

① Ignition Harness  
Harnais d'ignition

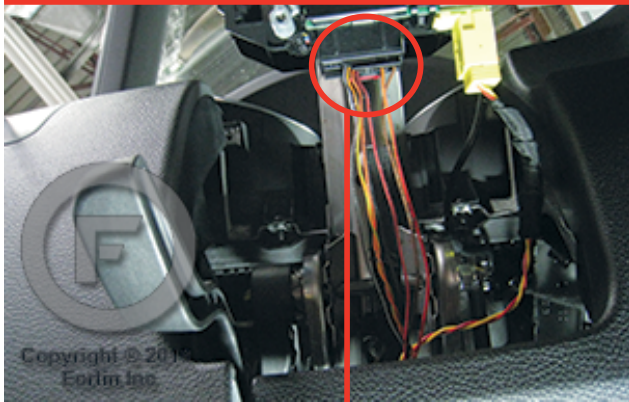

② Ignition barrel  
Barillet d'ignition

Black loom  
Gaine Noire

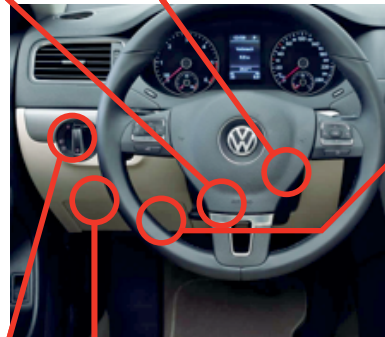
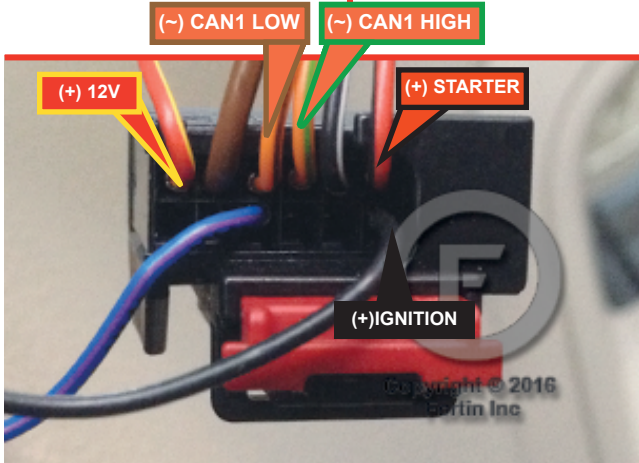
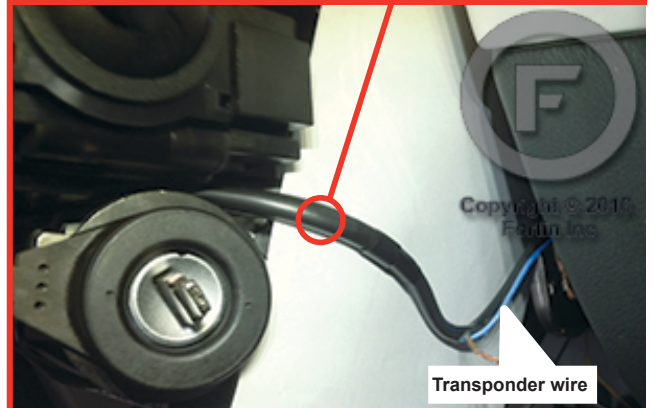

③ OBD-II connector  
Connecteur OBD-II

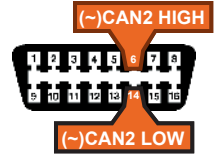

④ BCM

⑤ Parking light  
Feux de stationnement

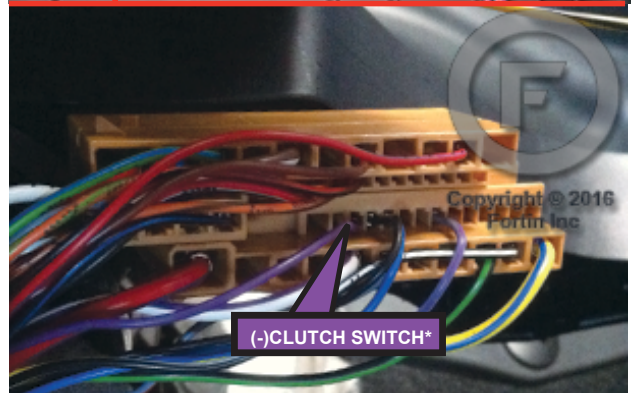
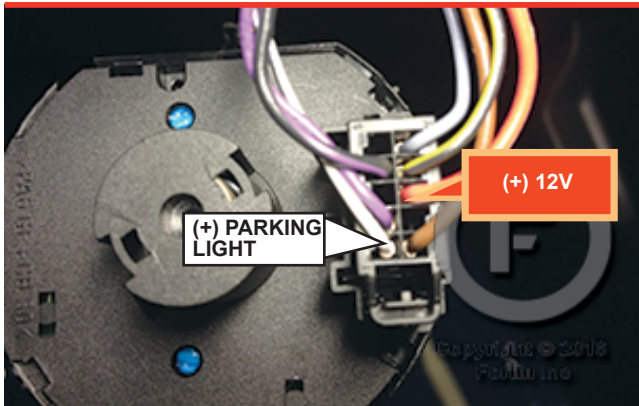

\*MANUAL TRANSMISSION  
\*TRANSMISSION MANUELLE

**AUTOMATIC TRANSMISSION WIRING CONNECTION | SCHÉMA DE BRANCHEMENT TRANSMISSION AUTOMATIQUE**

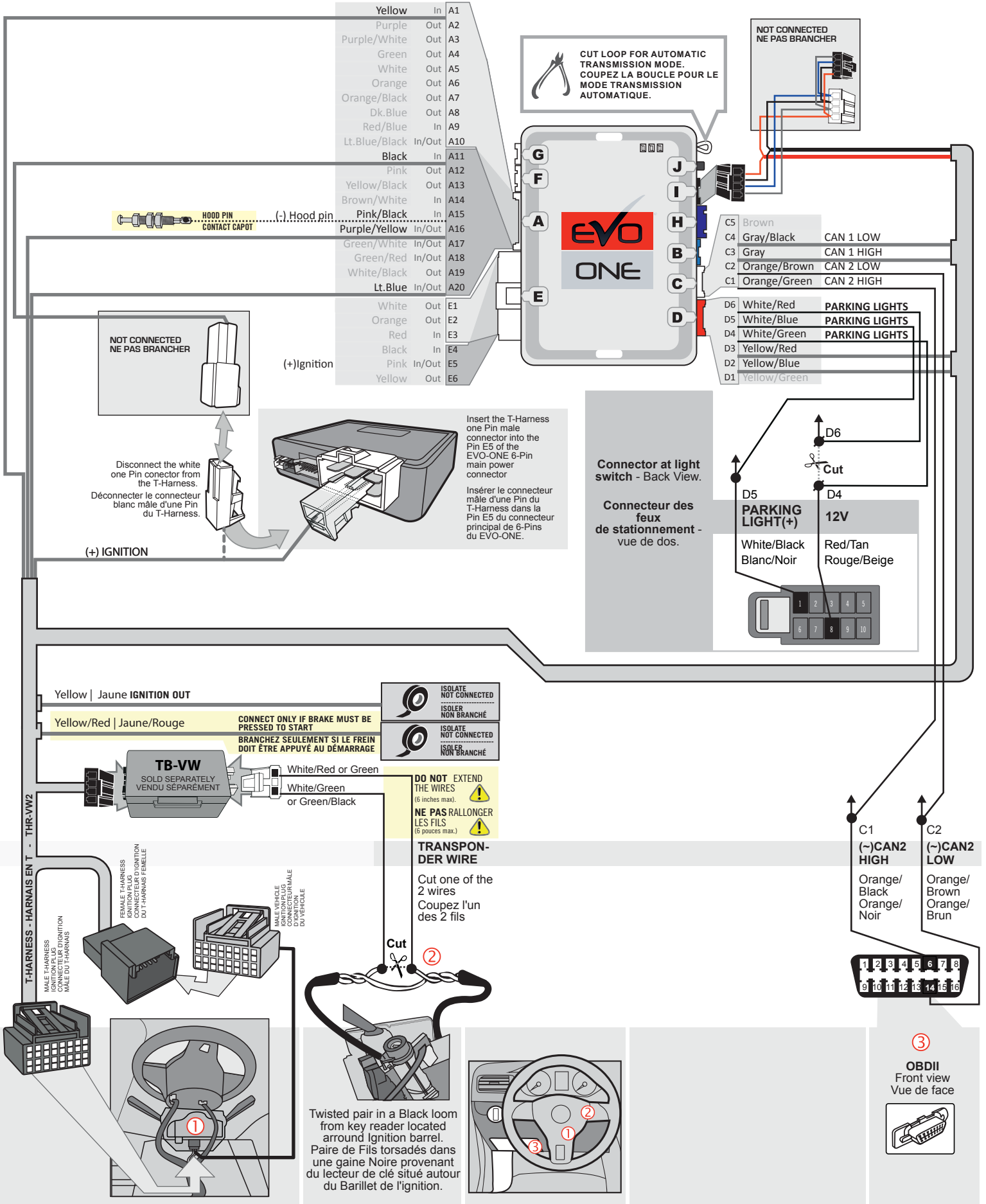





**DCRYPTOR PROGRAMMING PROCEDURE | PROCÉDURE DE PROGRAMMATION AVEC DCRYPTEUR**



Parts required (not included)

- 1x **FLASH LINK UPDATER 2**,
- 1x **FLASH LINK MANAGER** software
- 1x Microsoft Windows Computer with Internet connection

Pièces requises (non incluses)

- 1x **FLASH LINK UPDATER 2**,
- 1x Programme **FLASH LINK MANAGER**
- 1x Ordinateur Microsoft Windows avec connection Internet



1

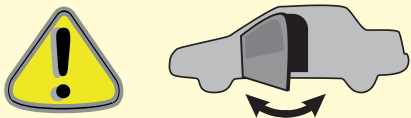

**WARNING:**  
Close and open the driver door.

**ATTENTION:**  
Fermez et ouvrez la porte conducteur.

2



Press and hold the programming button:  
Connect the 6-PIN Main harness (White connector).

Appuyez et maintenez le bouton de programmation enfoncé:  
Branchez le harnais Principal à 6-Broches (connecteur Blanc).

↳ The Blue, Red, Yellow and Blue & Red LEDs will alternatively illuminate.

↳ Les DELs Bleue, Rouge, Jaune et Bleue & Rouge illumineront alternativement.

3

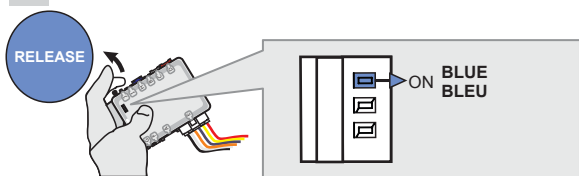

Release the programming button when the Blue LED is ON.

Relâchez le bouton de programmation quand la DEL Bleue est allumée.

If the LED is not solid BLUE, disconnect the 6-Pin connector (Main-Harness) and go back to step 1.

Si la DEL Bleue n'est pas allumée, débranchez le harnais Principal à 6-Broches et retournez au début de l'étape 1.

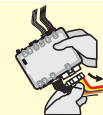

4

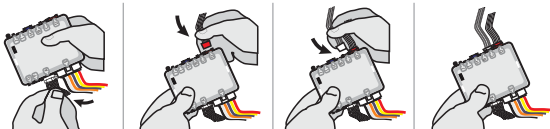

Connect the required remaining harnesses.

Branchez les harnais requis restants.

5

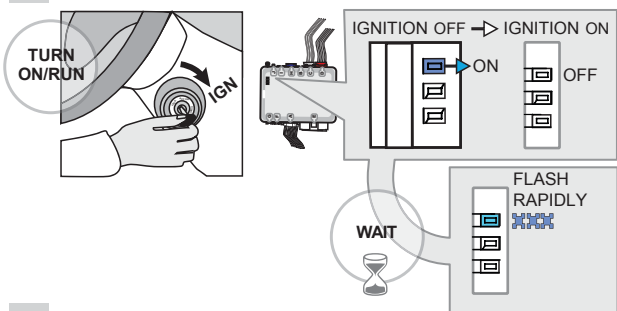

Turn the key to the Ignition ON/RUN position.

Tournez la clé à Ignition.

Wait,

↳ The BLUE LED will flash rapidly.

Attendez,

↳ La DEL BLEUE clignotera rapidement.

6

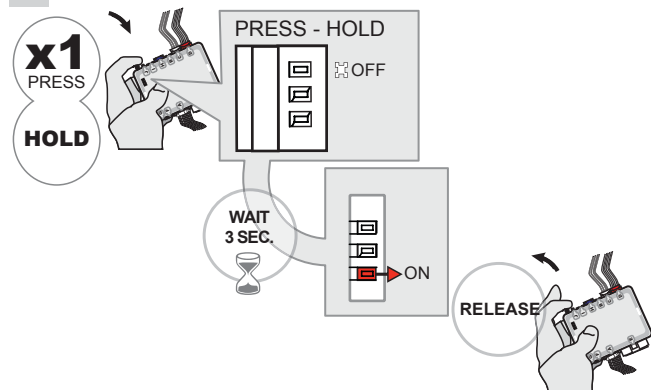

Press and hold the programming button.

Appuyez et gardez enfoncé le bouton de programmation.

↳ The BLUE LED will turn OFF.

↳ La DEL BLEUE s'éteint.

Wait,

↳ The RED LED will turn ON.

Attendez,

↳ La DEL ROUGE s'allume.

Release the programming button.

Relâchez le bouton de programmation.

**KEY BYPASS PROGRAMMING PROCEDURE 2/4 | PROCÉDURE DE PROGRAMMATION CONTOURNEMENT DE CLÉ 2/4**

7



**WAIT,**  
this process may take up  
to 15 minutes  
**Attendez,**  
ce processus peut prendre  
jusqu'à 15 minutes

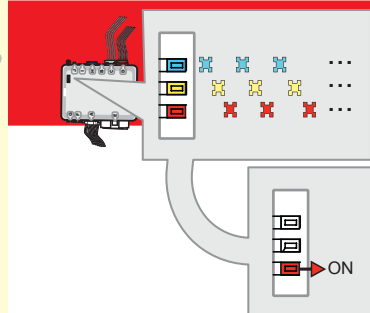

**Wait, do not touch the  
vehicle or the module.**

↳ The BLUE, RED and YELLOW  
LEDs will rapidly alternate.

**Wait,**

↳ the RED LED to turn ON.

**Attendez, ne touchez  
pas au véhicule ou au  
module.**

↳ Les DELs BLEUE, ROUGE  
et JAUNE alternent  
rapidement.

**Attendez,**

↳ DEL ROUGE s'allume.



8

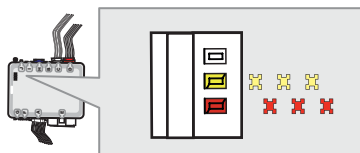

**Wait,**

↳ **Wait for the RED and YELLOW  
LEDs to slowly alternate.**

**Attendez,**

↳ **Attendez que les DELs ROUGE  
et JAUNE alternent doucement.**

*If the RED LED flashes slowly, the  
programming has failed, go back to  
step 1 and start the programming over.*

*Si la DEL ROUGE clignote  
lentement, la programmation a  
échoué, recommencez à l'étape 1.*

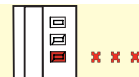

9

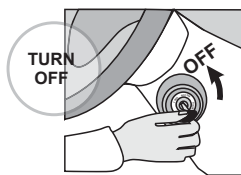

**Turn the key to the  
OFF position.**

**Tournez la clé à la  
position Arrêt (OFF).**

10

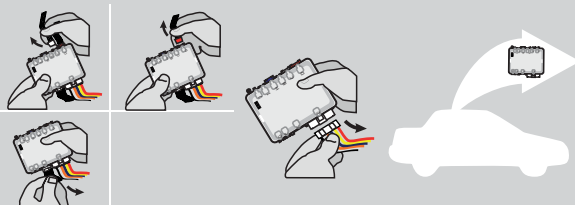

**Disconnect** all connectors and after the 6-Pin (Main-Harness)  
connector.

**Débranchez** tous les connecteurs et ensuite le connecteur  
6-pins (Connecteur principal).

11

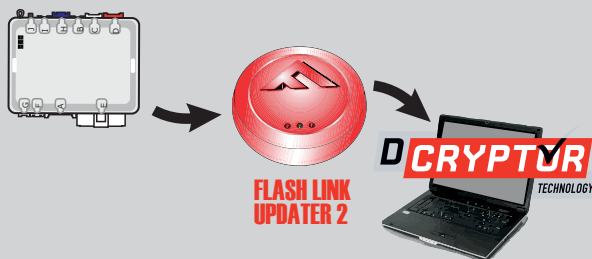

**Connect** the module to the  
FLASH LINK UPDATER 2  
and visit the DCryptor menu  
in the Flash-Link Manager.

**Branchez** le module au  
FLASH LINK UPDATER 2  
et visitez le menu DCryptor  
dans le Flash-Link Manager.

Parts required (not included)  
Pièces requises (non incluses)



**FLASH LINK  
UPDATER 2**

**FLASH LINK MANAGER**  
SOFTWARE | PROGRAMME



Microsoft Windows  
Computer with  
Internet connection  
Ordinateur Microsoft  
Windows avec  
connection Internet

12

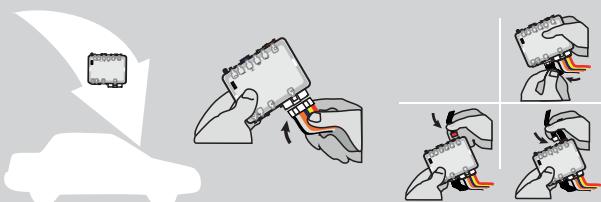

**AFTER DCRYPTOR PROGRAMMING COMPLETED**  
**Go** back to the vehicle and **reconnect** the 6-Pin (Main-  
Harness) connector and after all the remaining connector.

**APRÈS LA PROCÉDURE DE PROGRAMMATION  
DCRYPTOR COMPLÉTÉE :** retournez au véhicule et  
**rebranchez** le connecteur 6-pins (Connecteur principal)  
et après tous les connecteurs.

**KEY BYPASS PROGRAMMING PROCEDURE 3/4 | PROCÉDURE DE PROGRAMMATION CONTOURNEMENT DE CLÉ 3/4**

**13 AFTER HAVING PLUGGED IN THE POWER CONNECTOR:  
APRÈS AVOIR BRANCHER LE CONNECTEUR DE PUISSANCE:**

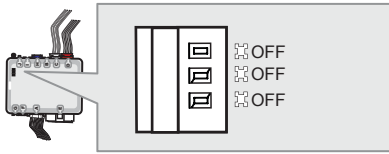

↳The RED and YELLOW LEDs stay OFF.

↳Les DELs ROUGE et JAUNE restent éteintes.

**OR  
OU**

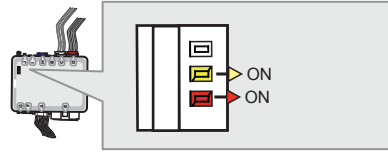

↳The RED and YELLOW LEDs turn ON.

↳Les DELs ROUGE et JAUNE s'allument.

*The module is now programmed.  
Le module est programmé*

**CONTINUED BELOW  
CONTINUEZ CI-DESSOUS**

**14**

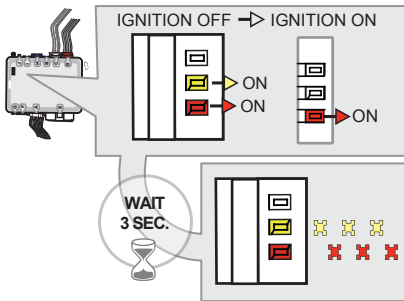
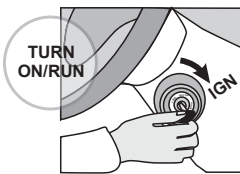

**Turn** the key to the Ignition ON/RUN position.

**Tournez** la clé à Ignition.

↳The YELLOW LED will turn OFF.

↳La DEL JAUNE s'éteint.

↳The RED and YELLOW LEDs will alternate.

↳La DEL ROUGE et JAUNE alternent.

**15**

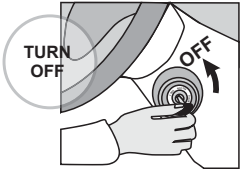

**Turn** the key to the OFF position.

**Tournez** la clé à la position Arrêt (OFF).



**16**

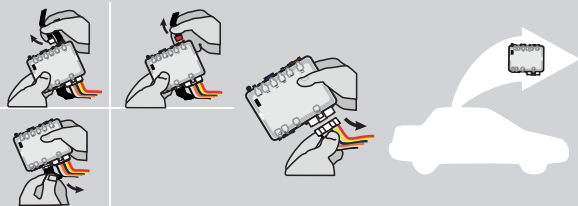

**Disconnect** all connectors and after the 6-Pin (Main-Harness) connector.

**Débranchez** tous les connecteurs et ensuite le connecteur 6-pins (Connecteur principal).

**17**

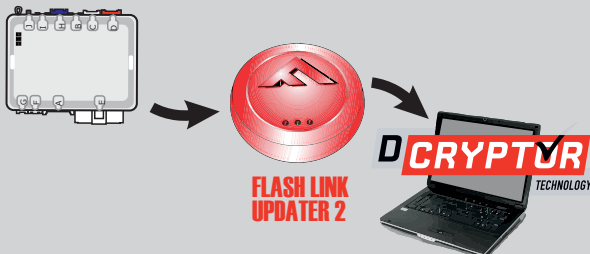

**Connect** the module to the FLASH LINK UPDATER 2 and visit the DCryptor menu in the Flash-Link Manager.

**Branchez** le module au FLASH LINK UPDATER 2 et visitez le menu DCryptor dans le Flash-Link Manager.

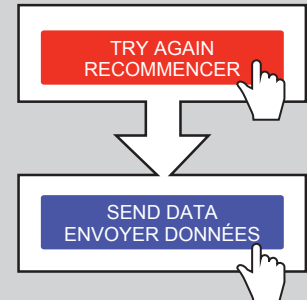

**KEY BYPASS PROGRAMMING PROCEDURE 4/4 | PROCÉDURE DE PROGRAMMATION CONTOURNEMENT DE CLÉ 4/4**

18

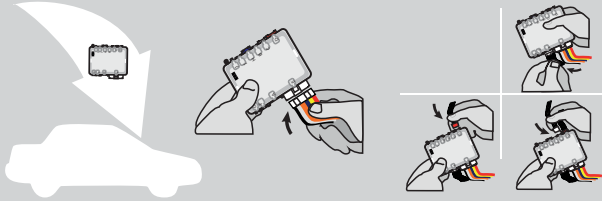

**AFTER DCRYPTOR PROGRAMMING COMPLETED**  
Go back to the vehicle and **reconnect** the 6-Pin (Main-Harness) connector and after all the remaining connector.

**APRÈS LA PROCÉDURE DE PROGRAMMATION DCRYPTOR COMPLÉTÉE :** retournez au véhicule et **rebranchez** le connecteur 6-pins (Connecteur principal) et après tous les connecteurs.



*The module is now programmed.  
Le module est programmé.*



**REMOTE STARTER / ALARM VERIFICATION PROCEDURE | PROCÉDURE DE VÉRIFICATION DU DÉMARREUR À DISTANCE / ALARME**

Test the remote starter. Remote start the vehicle.  
Testez le démarreur à distance. Démarrez le véhicule à distance.

**NOTE**

IF PROGRAMMING IS INTERRUPTED DURING THE PROCESS, SUCH AS A MODULE IS DISCONNECTED OR BY TURNING OFF THE IGNITION WITH THE KEY, IT IS POSSIBLE THAT THE VEHICLE WILL NO LONGER START NORMALLY, YOU MUST DISCONNECT AND RECONNECT THE VEHICLE BATTERY TO CORRECT THE SITUATION.



**NOTE**

SI LA PROGRAMMATION EST INTERROMPUE DURANT SON PROCESSUS, COMME PAR UN DÉBRANCHEMENT DU MODULE OU PAR LA FERMETURE DE LA CLÉ DE CONTACT, IL EST POSSIBLE QUE LE VÉHICULE NE PUISSE PLUS DÉMARRER NORMALEMENT, VOUS DEVREZ DÉBRANCHER ET REBRANCHER LA BATTERIE DU VÉHICULE POUR CORRIGER LA SITUATION.



**REMOTE STARTER PROGRAMMING PROCEDURE | PROCÉDURE DE PROGRAMMATION DU DÉMARREUR À DISTANCE**

 REFER TO THE **QUICK INSTALL GUIDE** INCLUDED WITH THE MODULE FOR THE REMOTE STARTER PROGRAMMING.

 RÉFÉREZ-VOUS AU **GUIDE D'INSTALLATION RAPIDE** INCLUS AVEC LE MODULE POUR LA PROGRAMMATION DU DÉMARREUR À DISTANCE.

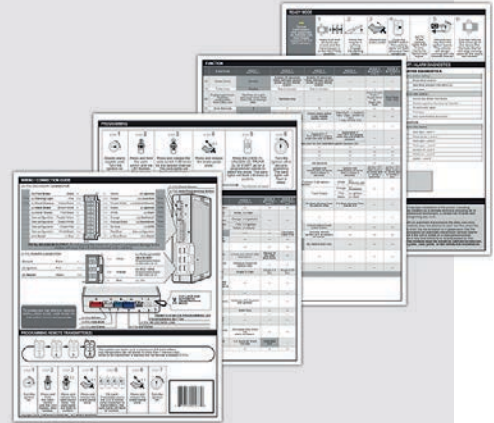

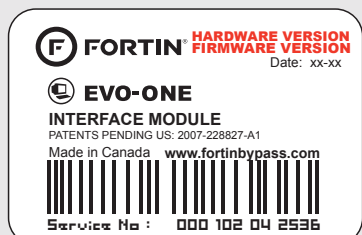

Module label | Étiquette sur le module

### Notice: Updated Firmware and Installation Guides

Updated firmware and installation guides are posted on our web site on a regular basis. We recommend that you update this module to the latest firmware and download the latest installation guide(s) prior to the installation of this product.

### Notice: Mise à jour microprogramme et Guides d'installations

Des mises à jour du Firmware (microprogramme) et des guides d'installation sont mis en ligne régulièrement. Vérifiez que vous avez bien la dernière version logiciel et le dernier guide d'installation avant l'installation de ce produit.

## WARNING

The information on this sheet is provided on an (as is) basis with no representation or warranty of accuracy whatsoever. It is the sole responsibility of the installer to check and verify any circuit before connecting to it. Only a computer safe logic probe or digital multimeter should be used. FORTIN ELECTRONIC SYSTEMS assumes absolutely no liability or responsibility whatsoever pertaining to the accuracy or currency of the information supplied. The installation in every case is the sole responsibility of the installer performing the work and FORTIN ELECTRONIC SYSTEMS assumes no liability or responsibility whatsoever resulting from any type of installation, whether performed properly, improperly or any other way. Neither the manufacturer or distributor of this module is responsible of damages of any kind indirectly or directly caused by this module, except for the replacement of this module in case of manufacturing defects. This module must be installed by qualified technician. The information supplied is a guide only. This instruction guide may change without notice. Visit [www.fortinbypass.com](http://www.fortinbypass.com) to get the latest version.

## MISE EN GARDE

L'information de ce guide est fournie sur la base de représentation (telle quelle) sans aucune garantie de précision et d'exactitude. Il est de la seule responsabilité de l'installateur de vérifier tous les fils et circuits avant d'effectuer les connexions. Seuls une sonde logique ou un multimètre digital doivent être utilisés. FORTIN SYSTÈMES ÉLECTRONIQUES n'assume aucune responsabilité de l'exactitude de l'information fournie. L'installation (dans chaque cas) est la responsabilité de l'installateur effectuant le travail. FORTIN SYSTÈMES ÉLECTRONIQUES n'assume aucune responsabilité suite à l'installation, que celle-ci soit bonne, mauvaise ou de n'importe autre type. Ni le fabricant, ni le distributeur ne se considèrent responsables des dommages causés ou ayant pu être causés, indirectement ou directement, par ce module, excepté le remplacement de ce module en cas de défaut de fabrication. Ce module doit être installé par un technicien qualifié. L'information fournie dans ce guide est une suggestion. Ce guide d'instruction peut faire l'objet de changement sans préavis. Consultez le [www.fortinbypass.com](http://www.fortinbypass.com) pour voir la plus récente version.

Copyright © 2006-2014, FORTIN AUTO RADIO INC ALL RIGHTS RESERVED PATENT PENDING



## TECH SUPPORT

Tél: 514-255-HELP (4357)  
1-877-336-7797



## ADDENDUM GUIDE

[www.fortinbypass.com](http://www.fortinbypass.com)

WEB UPDATE | MISE À JOUR INTERNET

