



COMPLETE INSTALLATION & PROGRAMMING GUIDE

MYCAR Telematics Communicator



This system must be installed by a professional.

NOTICE

manufacturer will accept no responsibility for any electrical damage resulting from improper installation of this product, be that either damage to the vehicle itself or to the installed device. This device must be installed by a certified technician. Please review the Installation Guide carefully before beginning any work.

Rev Date: 20161230
EN-20161230-A



TABLE OF CONTENTS

Hardware Parts.....	3
Fortin Evo-All.....	4
Fortin Evo-One	8
Reset Procedure.....	11



AR-3HU



HRN-MCAR-01





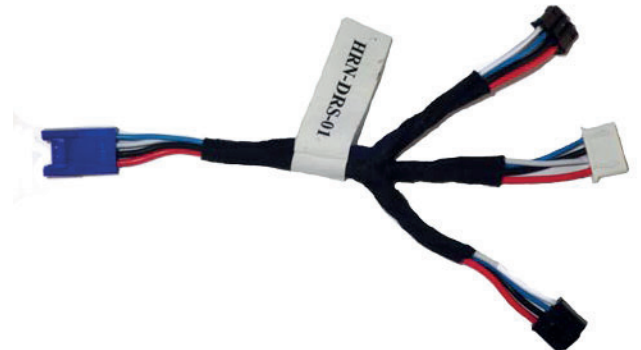

HRN-LLRS-01



HRN-DRS-01

REQUIRED PARTS FOR EVO-ALL INSTALLATION

MyCar Telematics device	HRN-MCAR-01	EVO-ALL	HRN-LLRS-01
			

STEP 1. CONFIGURE THE REMOTE STARTER

The Fortin Flashlink is required to properly configure the EVO-ALL remote starter to accept the MyCar telematics device. When flashing the EVO-ALL remote starter, please ensure to choose the following options: "C1 - OEM Remote starter", "D1 - 3x Lock start", "H2 - Fortin 2".

STEP 2. CONNECT

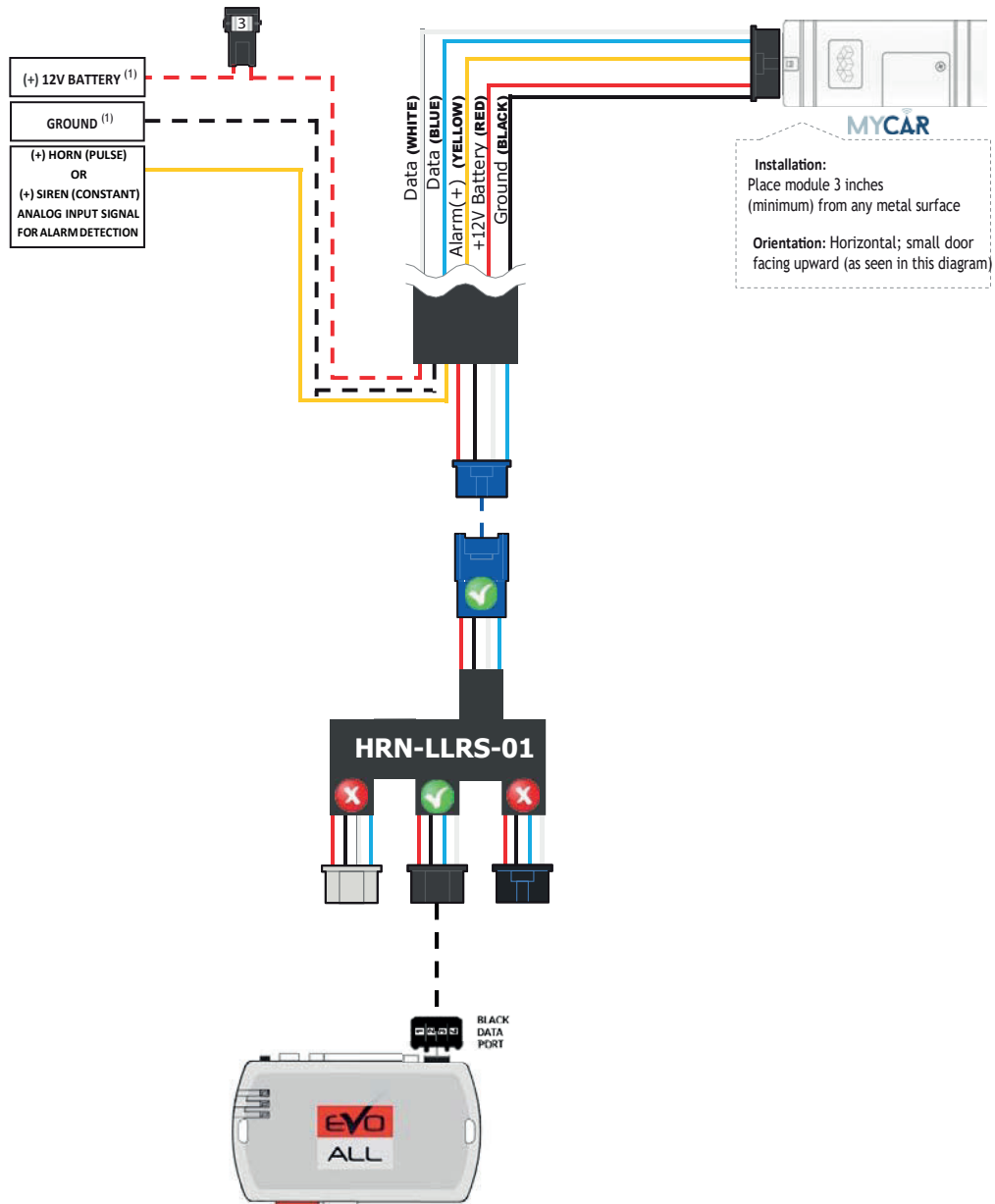

STEP 3. NETWORK CONNECTIVITY

Once the telematics module is connected into the remote starter, two LED's will display to which networks you are connected to. (See LED Status Reference Chart below). **NOTE: The vehicle may need to be outside in an open area in order to connect to a cellular and/or GPS network.**

LED Status Reference Chart		
LED Status	GREEN LED : Cellular Network	RED LED : GPS Network
OFF	No Cellular Network. No power to device.	No GPS Network. No power to device.
Flashing	Searching/Connecting	Searching/Connecting
ON Solid	Connection is established	Connection is established

STEP 4. INSTALL THE MYCAR APPLICATION

Go to the App store (Apple) or Play store (Android) and Search for "MYCAR CONTROLS". Download and install the Free Application.

STEP 5. CREATE AN ACCOUNT

NOTE: Already have an account? Go to the next step.

- Launch the newly installed MyCar Application on your smartphone or tablet
- Click "Create an Account"
- Fill in all the required fields
- Once completed, click "Create your Account"
- Open your Email and look for a new email sent from "MYCARCONTROLS"
- To activate your account and create your secure password, click the embedded link in the email.
- Create your secure password and activate your account.
- Once done, Log into the Application using your email and your newly created password.

STEP 6. ADD A DEVICE/VEHICLE TO AN ACCOUNT

- Click the "+" sign at the bottom right of the Application screen. This will allow you to temporarily add your customers device/vehicle to your personal account.
- Enter the 16 digit "Serial Number" found at the back of the device (SN: XXXXXX-XXXXXXXXXX) and Click "Submit the code".
- You are now in "Test Mode". Test Mode will allow you up to 4 hours for you to test the newly installed device. At any time during this 4 hour period, you can exit testing mode and make unit "Ready for Customer Delivery" by "Releasing the vehicle" or "Transferring the vehicle" from your account.
NOTE: If you do NOT remove the vehicle from your account, it will automatically be removed from your account and make the unit "Ready for Customer Delivery".

STEP 7. PRE-CONFIGURE MYCAR APPLICATION EXPERIENCE FOR YOUR CUSTOMER

- Click on the vehicle to enter the control screen (the screen that will allow you to control the vehicles' remote start functions). This will automatically take you to the "Vehicle Configuration" page for this vehicle. You will be prompt to "Set a Bypass Protocol" to use this device. Click "Ok".
- Now you must set the protocol for the MyCar device. When combined with the Evo-All remote starter previously installed, you must set the protocol to "Fortin" and click "ACCEPT".
- Then from the top of the Settings section edit the Vehicle name, configure the Auxiliaries that might have been added if applicable and click ACCEPT when done. Then choose the vehicle to display in the control panel in the VEHICLE IMAGE section and click ACCEPT once done.
- When your configurations are all completed, click "Done" at the top right corner. All Configurations will take effect.
- Now please allow a moment for the MyCar device to update your protocol selection and be available to accept commands from the App. In the vehicle control screen, the Device Signal icon located above the Stop button will display the connectivity status of your MyCar device. If the icon is Grayed out, Please wait, Device is still Offline. If icon is Green, Device is Online and Ready to go.

STEP 8. LEARN THE TELEMATICS DEVICE TO THE EVO-ALL

In order to communicate with the remote starter, the MyCar must be learned to the EVO-ALL.





- 1 - Disconnect the Black 4 pin power connector from the Evo-All.
- 2 - Press and Hold the Programming button on the Evo-All while plugging back the Black 4 pin connector.
- 3 - The LED's on the Evo-All will begin to cycle. Keep pressing the programming button until the RED and BLUE LED's are On.
- 4 - Release the programming button.
- 5 - Press and Hold the programming button again for 5 seconds. The BLUE and RED LED's will blink once.
- 6 - Release the programming button.
- 7 - Cycle the ignition to the ON position.
- 8 - The RED, YELLOW and BLUE LED's will be ON.
- 9 - Seconds later the RED and BLUE LED's will blink once to confirm that the MyCar ID has been learned to the Evo-All.
- 10 - Cycle the vehicle's ignition to the OFF position to Exit EVO-ALL programming.

STEP 9. TEST YOUR DEVICE

Once in the vehicle control panel and the system is Online you can test the unit. Test all the application functions (Start, Stop, Lock, Unlock, Auxiliaries, ETC.) When done with the testing, release or transfer the vehicle from your account to make it "Ready for Customer Delivery".

Also make sure that the MyCar Owners Card is handed to the Owner of the vehicle. Doing this will ensure that the instructions on how to setup their App, Account and Vehicle is done correctly by using the device serial number located on the sticker affix by the installer at the time of installation

REQUIRED PARTS FOR EVO-ONE INSTALLATION

MyCar Telematics device	HRN-MCAR-01	EVO-ONE	HRN-LLRS-01
			

STEP 1. CONFIGURE THE REMOTE STARTER

The Fortin Flashlink is required to properly configure the EVO-ONE remote starter to accept the MyCar telematics device. When flashing the EVO-ONE remote starter, please ensure to choose the following options: Toggle your Flashlink connection mode to "Remote-Starter". From the top menu click on "Configuration" and then on "Unit Options". In the "RF Kit Compatible" section, check the box next to "Fortin 2" and click the save button on the top right of the screen.

STEP 2. CONNECT

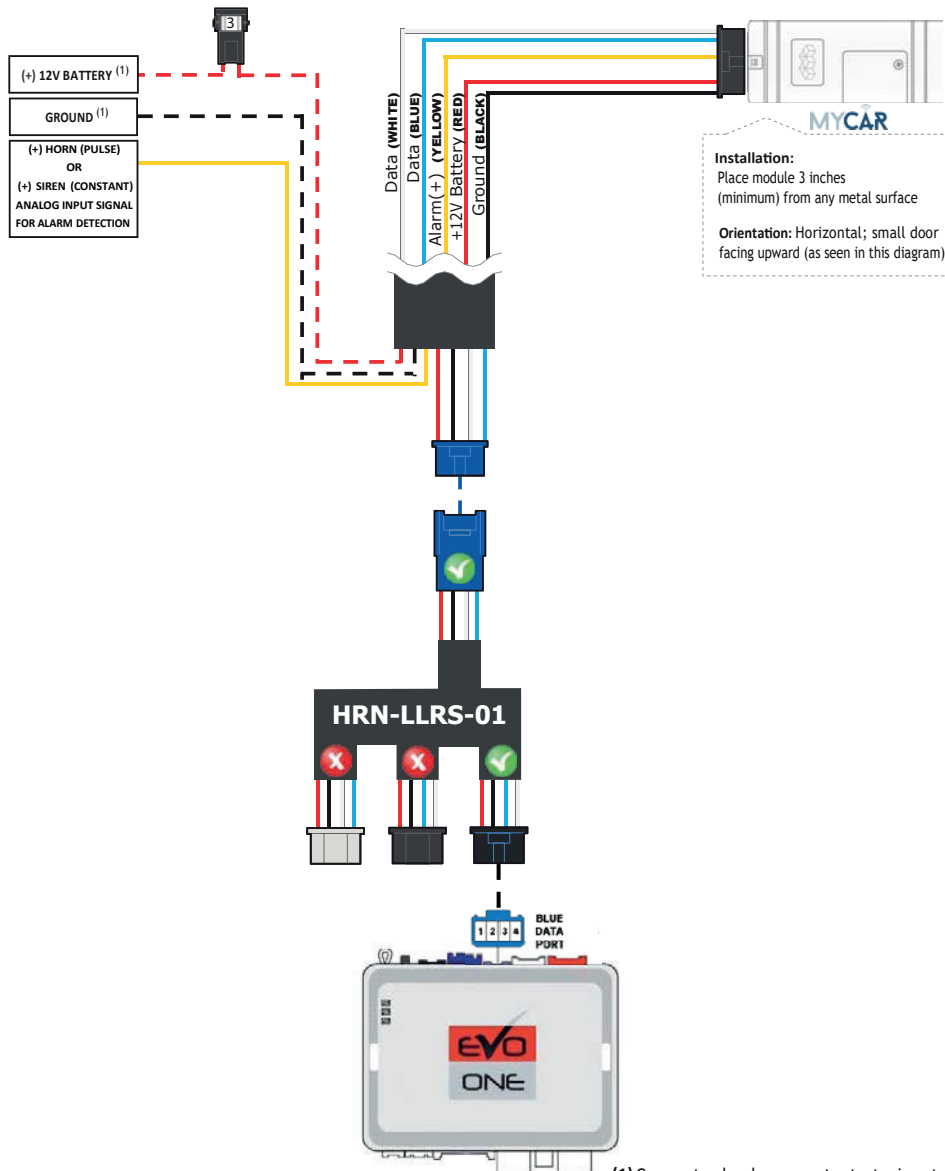

(1) Connect only when remote starter is not supplying power to telematics device

STEP 3. NETWORK CONNECTIVITY

Once the telematics module is connected into the remote starter, two LED's will display to which networks you are connected to. (See LED Status Reference Chart below). **NOTE: The vehicle may need to be outside in an open area in order to connect to a cellular and/or GPS network.**

LED Status Reference Chart

LED Status	GREEN LED : Cellular Network	RED LED : GPS Network
OFF	No Cellular Network. No power to device.	No GPS Network. No power to device.
Flashing	Searching/Connecting	Searching/Connecting
ON Solid	Connection is established	Connection is established

STEP 4. INSTALL THE MYCAR APPLICATION

Go to the App store (Apple) or Play store (Android) and Search for "MYCAR CONTROLS". Download and install the Free Application.

STEP 5. CREATE AN ACCOUNT

NOTE: Already have an account? Go to the next step.

- a. Launch the newly installed MyCar Application on your smartphone or tablet
- b. Click "Create an Account"
- c. Fill in all the required fields
- d. Once completed, click "Create your Account"
- e. Open your Email and look for a new email sent from "MYCARCONTROLS"
- f. To activate your account and create your secure password, click the embedded link in the email.
- g. Create your secure password and activate your account.
- h. Once done, Log into the Application using your email and your newly created password.

STEP 6. ADD A DEVICE/VEHICLE TO AN ACCOUNT

- a. Click the "+" sign at the bottom right of the Application screen. This will allow you to temporarily add your customers device/vehicle to your personal account.
- b. Enter the 16 digit "Serial Number" found at the back of the device (SN: XXXXXX-XXXXXXXXXX) and Click "Submit the code".
- c. You are now in "Test Mode". Test Mode will allow you up to 4 hours for you to test the newly installed device. At any time during this 4 hour period, you can exit testing mode and make unit "Ready for Customer Delivery" by "Releasing the vehicle" or "Transferring the vehicle" from your account.
NOTE: If you do NOT remove the vehicle from your account, it will automatically be removed from your account and make the unit "Ready for Customer Delivery".

STEP 7. PRE-CONFIGURE MYCAR APPLICATION EXPERIENCE FOR YOUR CUSTOMER

- a. Click on the vehicle to enter the control screen (the screen that will allow you to control the vehicles' remote start functions). This will automatically take you to the "Vehicle Configuration" page for this vehicle. You will be prompt to "Set a Bypass Protocol" to use this device. Click "Ok".
- b. Now you must set the protocol for the MyCar device. When combined with the Evo-All remote starter previously installed, you must set the protocol to "Fortin" and click "ACCEPT".
- c. Then from the top of the Settings section edit the Vehicle name, configure the Auxiliaries that might have been added if applicable and click ACCEPT when done. Then choose the vehicle to display in the control panel in the VEHICLE IMAGE section and click ACCEPT once done.
- d. When your configurations are all completed, click "Done" at the top right corner. All Configurations will take effect.
- e. Now please allow a moment for the MyCar device to update your protocol selection and be available to accept commands from the App. In the vehicle control screen, the Device Signal icon located above the Stop button will display the connectivity status of your MyCar device. If the icon is Grayed out, Please wait, Device is still Offline. If icon is Green, Device is Online and Ready to go.

STEP 8. LEARN THE TELEMATICS DEVICE TO THE EVO-ONE

In order to communicate with the remote starter, the MyCar must be learned to the EVO-ONE.

- 1 - Cycle the ignition to the ON position.
- 2 - The YELLOW LED on top of the EVO-ONE should come ON.
- 3 - Press and Hold the EVO-ONE push button for 5 seconds.
- 4 - The parking lights and the RED LED on the side of the EVO-ONE will turn ON.
- 5 - Release the push button.
- 6 - Press and Release the push button 5x times. Everytime the push button is pressed the parking lights and the RED Led on the side of the EVO-ONE will blink.
- 7 - Then Press and Release the Brake pedal.
- 8 - Seconds later the RED LED on the side of the EVO-ONE will blink once to confirm that the MyCar ID has been learned to the EVO-ONE.
- 9 - Cycle the vehicle's ignition to the OFF position to Exit the EVO-ONE programming.

STEP 9. TEST YOUR DEVICE

Once in the vehicle control panel and the system is Online you can test the unit. Test all the application functions (Start, Stop, Lock, Unlock, Auxiliaries, ETC.) When done with the testing, release or transfer the vehicle from your account to make it "Ready for Customer Delivery".

Also make sure that the MyCar Owners Card is handed to the Owner of the vehicle. Doing this will ensure that the instructions on how to setup their App, Account and Vehicle is done correctly by using the device serial number located on the sticker affix by the installer at the time of installation.

RESET PROCEDURE

- 1 - Disconnect the main harness from the MyCar device.
- 2 - Wait approximately 10 seconds and reconnect the main harness to the MyCar device.
- 3 - This will complete the reset procedure.

MYCAR

400 Wright - St-Laurent, Quebec, H4N1M6 - CANADA

© 2016 MyCar Controls. All rights reserved.