



REVO

GUIDE # 88761 - REV.: 20190715



Parts required (not included):

1x **FLASH-LINK UPDATER**

1x Microsoft Windows Computer with Internet connection

1

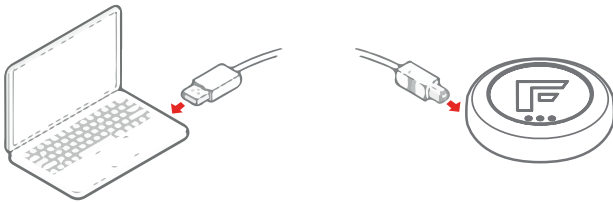

Plug in the **FLASH-LINK UPDATER** into the computer's USB port with the provided USB cable.

2



Run Flash Link Manager Software.

3

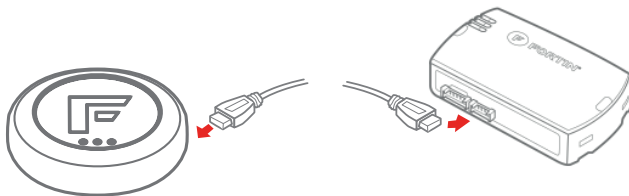

Plug in the **EVO-ALL** into the **FLASH-LINK UPDATER** with provided **DATALINK** cable.

Fortin FlashLink Manager
File Tools Configuration Help

FlashLink Manager

See All Notes Open Notices

BYPASS GUIDES HELP CENTER VIDEOS BUG REPORT Options Saved

BYPASS OPTIONS
DCRYPTOR

FIRMWARE
FIRMWARE INSIDE 75.[38]
HARDWARE INSIDE 6.0
VIEW OTHER FIRMWARES

RECOMMENDED FIRMWARE IS LOADED
75.[38] RECOMMENDED

LOAD SUGGESTED OPTIONS SAVE OPTIONS

Options Saved

Collapse Options Expand Options

D5	LOCK AFTER START	Lock the doors after remote start.	OFF	ON	
D6	PUSH-TO-START		OFF	ON	
D7	RAP DISABLE		OFF	ON	
SPECIAL FUNCTIONS					
DATALINK PROTOCOLS					
G	EVO ALARM SYSTEM	Compatible with OEM remotes and RF kit antenna.	OFF	ON	
H	SUPPORTED RF KITS		OFF	ON	
H1	FORTIN	Fortin (AST, DSE, Atom, etc.)	OFF	ON	
H2	FORTIN 2	Fortin2 (FMH, EVO-START...) Autocconnect	OFF	ON	
H3	CRIMESTOPPER		OFF	ON	
H4	AUDIOVOX FLRF, DEI SMARTSTART		OFF	ON	
H5	DEI XL202		OFF	ON	
H6	FT-D100		OFF	ON	

FLASH-LINK UPDATER STATUS: CONNECTED
EVO-ALL STATUS: CONNECTED

Device Found | Unit Disconnected | Firmware: 75.38 | Firmware Selected: N/A | Connection mode: Bypass

4

- A. Click on BYPASS tab.
- B. Activate Supported RF Kits to ON
- C. Activate Option H3 – CrimeStopper
- D. Click SAVE OPTIONS
- E. Wait for the Options Saved message to appear in the top right corner.

5

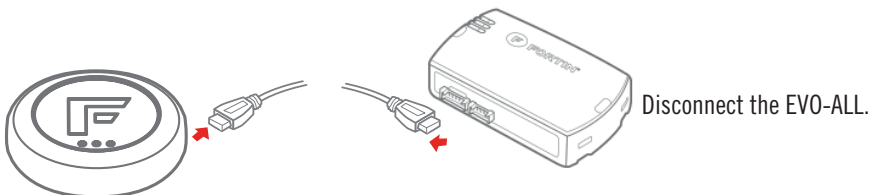

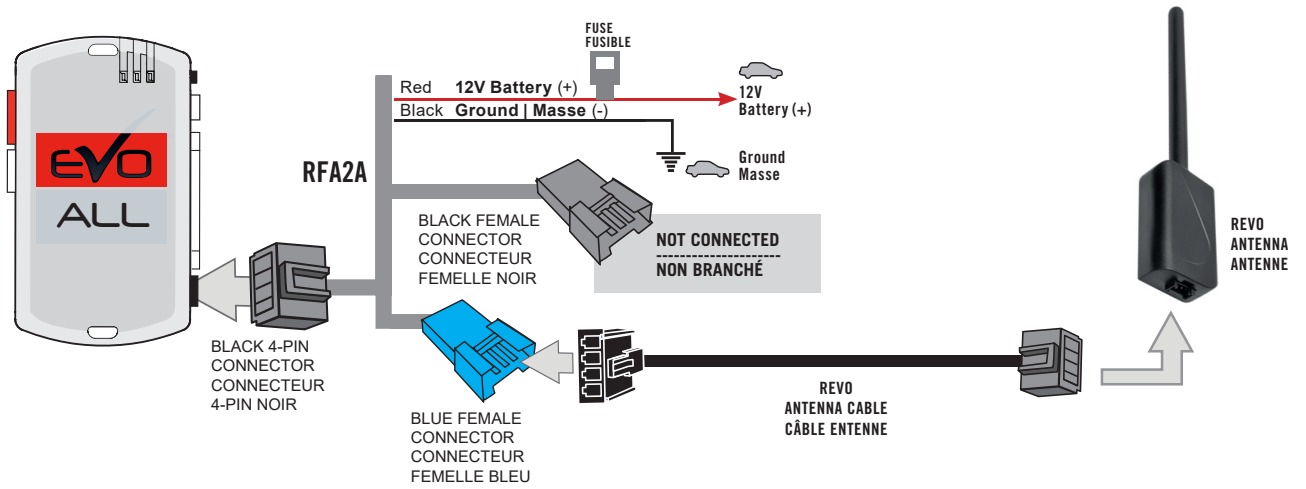

6

WITH T-HARNESS - AVEC T-HARNAIS

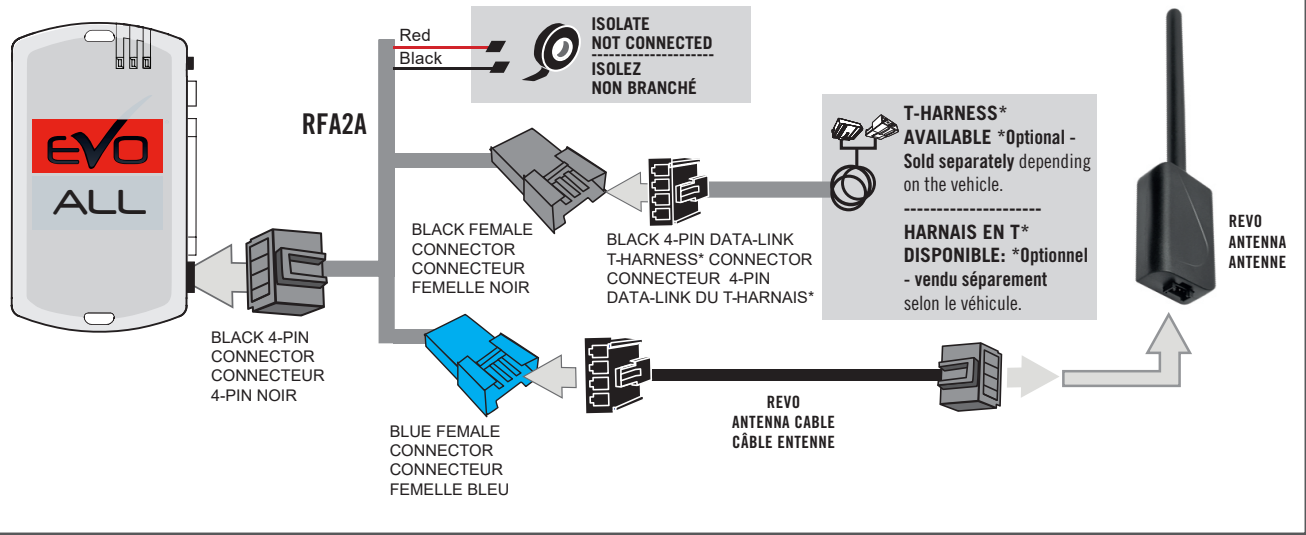

Connect both modules together as shown.

TO PROGRAM REMOTES ON THE UNITS

WITH EVO-ALL MODULE

- 1**

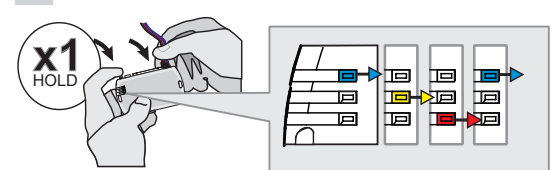

x1 HOLD

Press and hold the programming button: Insert the 4-Pin (Data-Link) connector.

↳ The Blue, Red, Yellow and Blue & Red LED's will alternatively illuminate.
- 2**

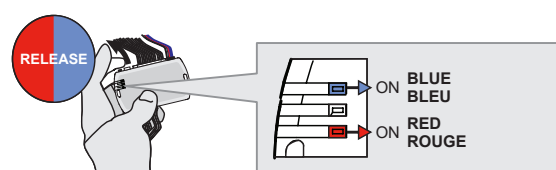

RELEASE

Release the programming button when the LED's are RED and BLUE.

If the LED are not solid BLUE and RED disconnect the 4-Pin connector (Data-Link) and go back to step 1.
- 3**

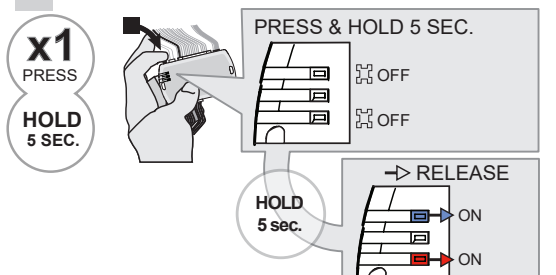

x1 PRESS
HOLD 5 SEC.

PRESS & HOLD 5 SEC.

OFF OFF

ON ON

HOLD 5 sec.

RELEASE

Press and hold the programming button 5 seconds.

↳ The RED and BLUE LED's will turn OFF.

Release the programming button.

↳ The RED and BLUE LED's will turn ON.
- 4**

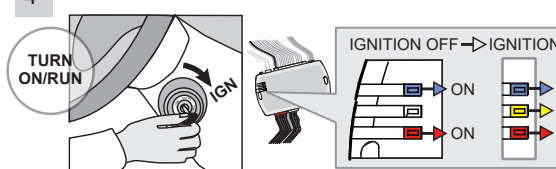

TURN ON/RUN

IGNITION OFF → IGNITION ON

ON ON ON

Turn the Ignition to the ON/RUN position.

↳ The YELLOW LED will turn ON.
- 5**

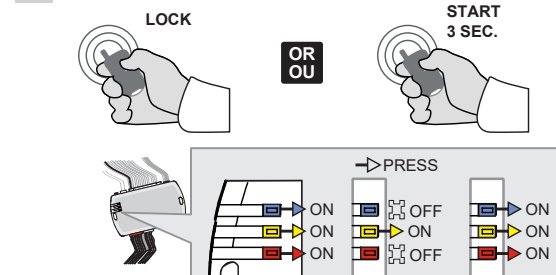

LOCK **OR** **START 3 SEC.**

PRESS

OFF OFF ON ON

ON ON ON ON

Press the LOCK button on remotes you wish to program. (You can also press the "Start" button, but you will have to hold it for 3 seconds.)

All remotes must be program at the same time.

↳ The BLUE and RED LED's will flash once to confirm remote is coded.
- 6**



TURN OFF

Turn the Ignition to the OFF position.

WITH IGNITION SWITCH

- 1**



Turn the Ignition ON.
- 2**



Turn the Ignition OFF.
- 3**

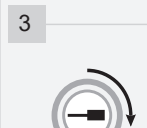

Turn the Ignition ON.
- 4**



Press and release the brake pedal four times.
- 5**



On each Transmitter press and release the LOCK button
- 6**



Turn the Ignition OFF.

The remotes is now programmed.

Use the remote of the remote starter or security system to test all of the supported features to ensure proper programming.

The remotes are now programmed.

Use the remote of the remote starter or security system to test all of the supported features to ensure proper programming.

WARNING

NOTICE The manufacturer will accept no responsibility for any electrical damage resulting from improper installation of the product, including either damage to the vehicle itself or to the remote-starter module. This module must be installed by a certified technician including all of the supplied safety devices. Please note that this guide has been written for trained professional technicians, a certain level of skills and knowledge is therefore assumed.

Neither the manufacturer or distributor of this module is responsible of damages of any kind indirectly or directly caused by this module, except for the replacement of this module in case of manufacturing defects. This module must be install by qualified technician. This instruction guide may change without notice.

To download the installation guide, user guide, or the latest quick installation guide, visit: www.fortin.ca

Technical support: TEL: 514-255-4357 / 1-877-336-7797

Copyright © 2019, FORTIN AUTO RADIO INC ALL RIGHTS RESERVED MADE IN CANADA

REV.:20190517