

# THAR-ONE-HON8 INSTALLATION WITH TAKE OVER INSTALLATION THAR-ONE-HON8 AVEC PRISE EN CHARGE

 ADDENDUM - SUGGESTED WIRING CONFIGURATION  
 ADDENDA - SCHÉMA DE BRANCHEMENT SUGGÉRÉ

Vehicle functions supported in this diagram (functional if equipped) | Fonctions du véhicule supportées dans ce diagramme (fonctionnelles si équipé)

	Immobilizer bypass Contournement d'immobilisateur	T-Harness Harnais en T	Lock	Unlock	Arm	Disarm	Trunk (open)	Horn	Parking Lights	Auto Lights OFF	Tachometer	Door Status	Trunk Status	Hood Status*	Hand-Brake Status	Foot-Brake Status	OEM Remote Monitoring	R.S. OEM remote Stand Alone compatible	YEARS ANNÉES
																			ILX

**ACURA**

Push-to-Start 2016-2022

**BYPASS FIRMWARE VERSION  
VERSION LOGICIELLE CONTOURNEMENT**
**73.[38]**

HONDA/ACURA MINIMUM

 To add the firmware version and the options, use the **FLASH LINK UPDATER** or **FLASH LINK MOBILE** tool, sold separately.

 Pour ajouter la version logicielle et les options, utilisez l'outil **FLASH LINK UPDATER** ou **FLASH LINK MOBILE**, vendu séparément.

**Program bypass option:  
Programmez l'option du contournement:**
**UNIT OPTION  
OPTION UNITE**
**DESCRIPTION**
**C1**

 OEM Remote status (Lock/Unlock) monitoring  
Suivi des status (Verrouillage/Déverrouillage) de la télécommande d'origine

**D6**

 Push-to-Start  
Push-to-Start

**Program bypass option  
(If equipped with OEM alarm):  
Programmez l'option du contournement  
(Si équipé d'une alarme d'origine):**
**UNIT OPTION  
OPTION UNITE**
**DESCRIPTION**
**D2**

 Unlock before / Lock after (Disarm OEM alarm)  
Déverrouille avant / Verrouille après (Désarme l'alarme d'origine)

**Program remote starter option for R.S. OEM REMOTE STAND ALONE:  
Programmez l'option démarreur à distance pour TÉLÉCOMMANDE D'ORIGINE STAND ALONE:**
**FUNCTION  
FONCTION**
**MODE**
**DESCRIPTION**
**38**
**2**

 Enable  
Press 3x Lock to remote start with the OEM remote.  
Activé  
Appuyez x3 sur Verrouille de la télécommande d'origine pour démarrer à distance le véhicule.

**MANDATORY INSTALL | INSTALLATION OBLIGATOIRE**
**\* HOOD  
PIN  
CONTACT  
DE CAPOT**

**HOOD STATUS:** THE HOOD PIN SWITCH (INCLUDED) MUST BE INSTALLED IF THE VEHICLE CAN BE REMOTE STARTED WITH THE HOOD OPEN, SET FUNCTION A11 TO OFF.  
**STATUT DE CAPOT:** LE CONTACT DE CAPOT (INCLUS), DOIT ÊTRE INSTALLÉ SI LE VÉHICULE PEUT DÉMARRER À DISTANCE, LORSQUE LE CAPOT EST OUVERT, PROGRAMMEZ LA FONCTION A11 À NON.

**A11**
**OFF  
NON**
**SECURITY STICKER  
AUTOCOLLANT DE  
SÉCURITÉ**

 Included  
Inclus

**Notice:** the installation of safety elements are mandatory. The hood pin and the sticker are essential security elements and must be installed.  
**Notice:** l'installation des éléments de sécurité est obligatoire. Le contact de capot et l'autocollant de sécurité sont des éléments de sécurité essentiels et doivent absolument être installés.

THIS MODULE MUST BE INSTALLED BY A QUALIFIED TECHNICIAN. A WRONG CONNECTION CAN CAUSE PERMANENT DAMAGE TO THE VEHICLE.

CE MODULE DOIT ÊTRE INSTALLÉ PAR UN TECHNICIEN QUALIFIÉ, TOUTE ERREUR DANS LES BRANCHEMENTS PEUT OCCASIONNER DES DOMMAGES PERMANENTS AU VÉHICULE.

**DESCRIPTION | DESCRIPTION**

③ At Parking Light Harness  
Au Harnais des feux de stationnement

(-) Parking Lights



① ② At Smart PCU Module, Above gas pedal  
Au module Smart PCU, au dessus de la pédale de gaz

③ At steering lock module under steering column  
Au module verrouillage de la colonne sous la colonne de direction

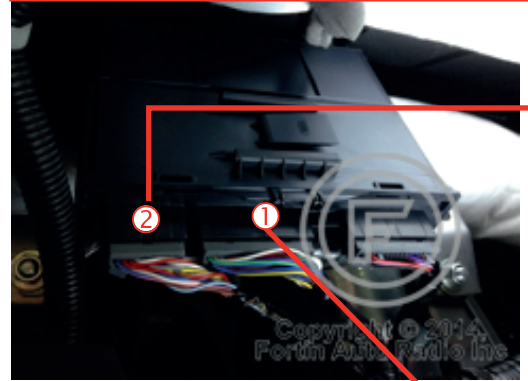
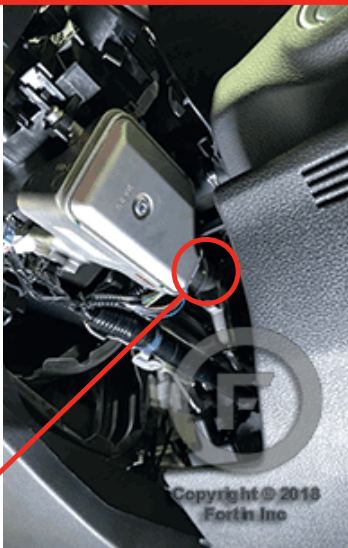

①

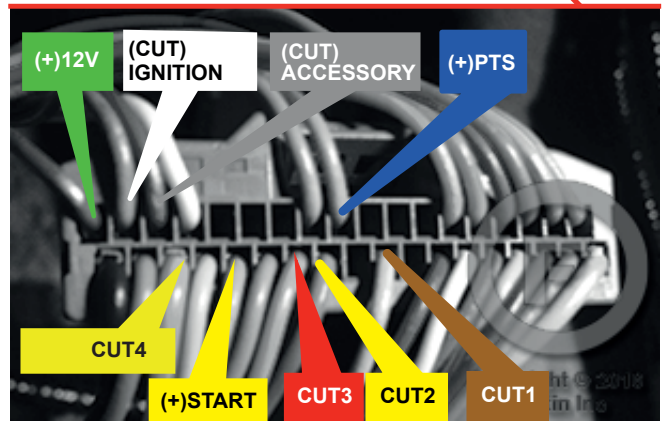

②

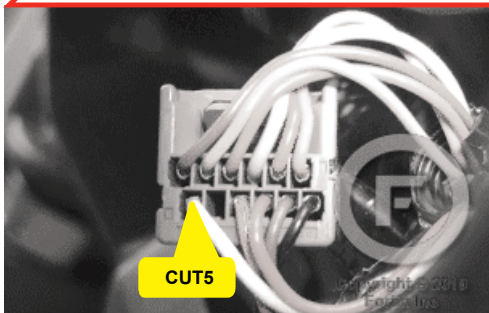
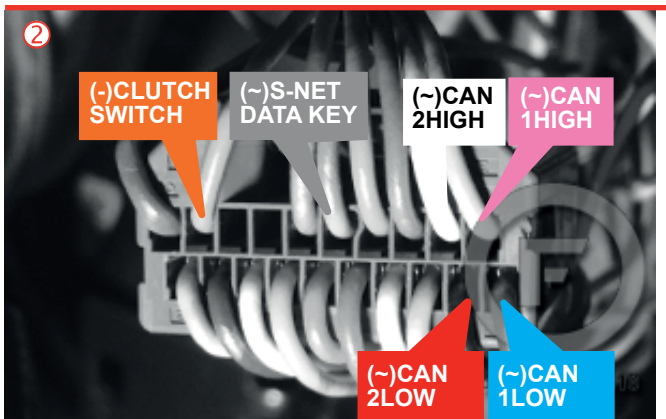

ILX

 Parts required (Not included)	Pièce(s) requise(s) (Non incluse(s))
1X Fuse	1X Fusible
2X Relays	2X Relais
2X Diodes	2X Diodes

\*(-)CLUTCH  
Manual transmission  
Transmission manuelle

**AUTOMATIC TRANSMISSION WIRING CONNECTION | SCHÉMA DE BRANCHEMENT TRANSMISSION AUTOMATIQUE**

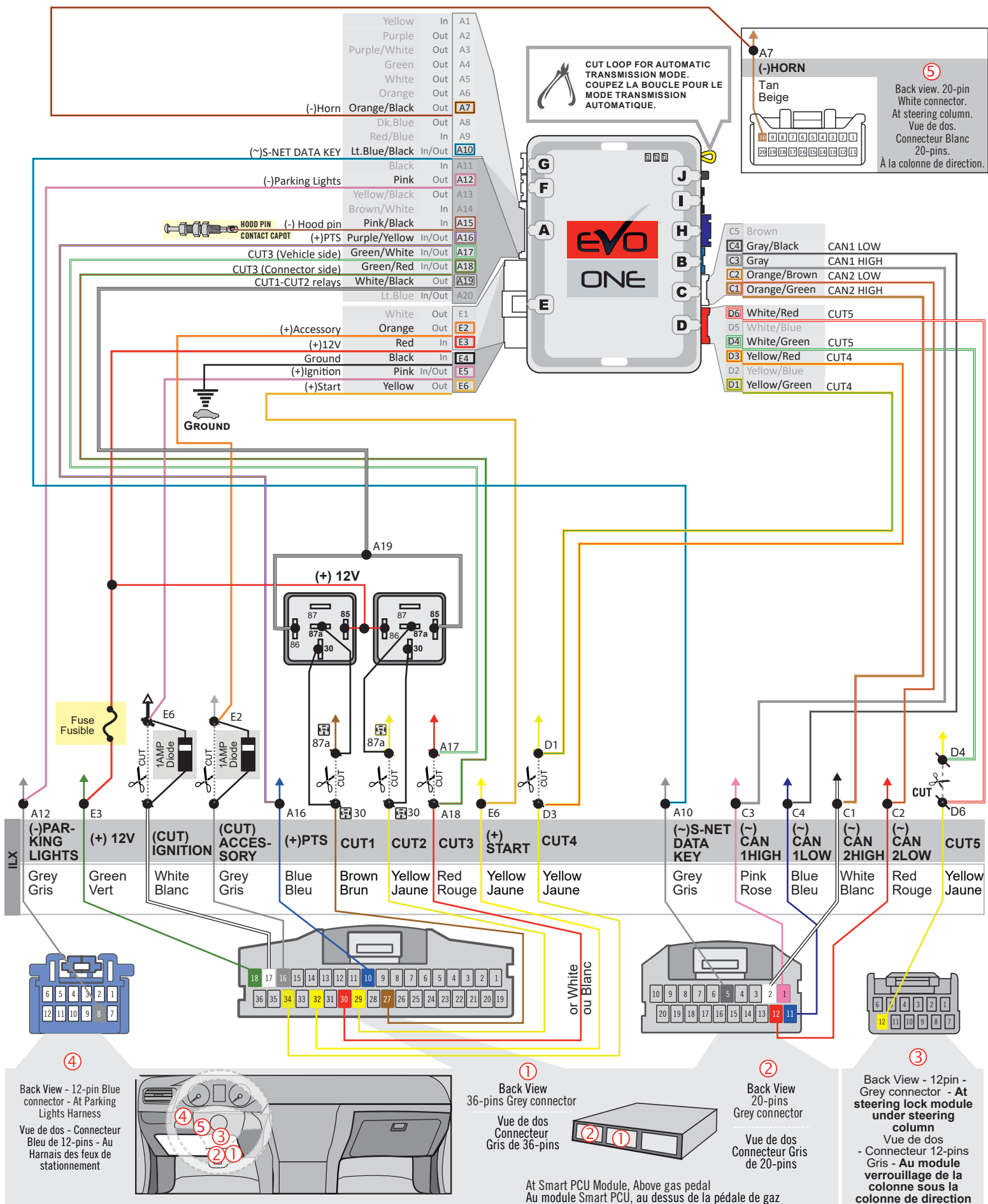

**MANUAL TRANSMISSION WIRING CONNECTION | SCHÉMA DE BRANCHEMENT TRANSMISSION MANUELLE**

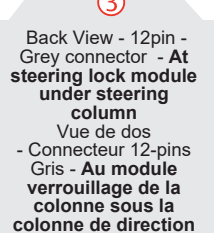
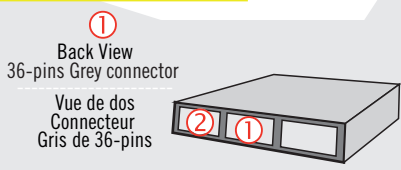
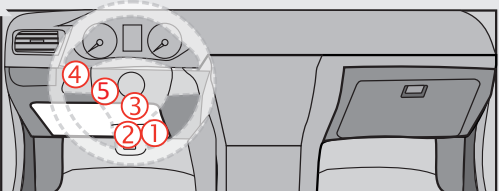
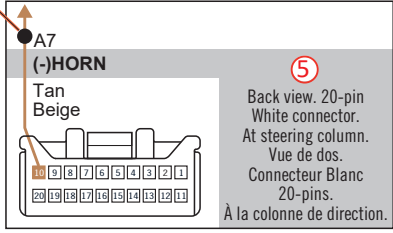
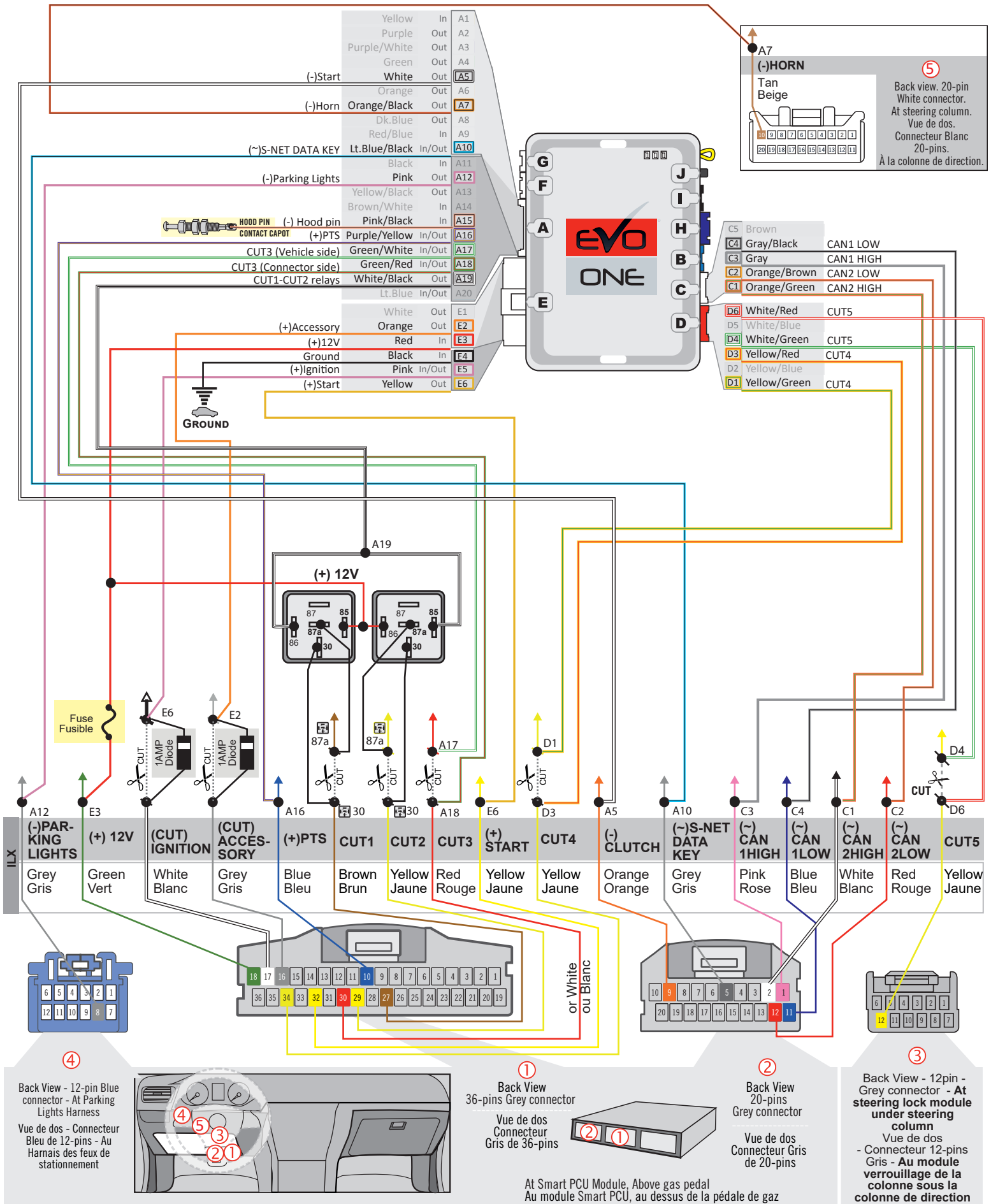

At Smart PCU Module, Above gas pedal  
Au module Smart PCU, au dessus de la pédale de gaz

THAR-ONE-HON8 | T-HARNESS - AUTOMATIC TRANSMISSION | T-HARNAIS - TRANSMISSION AUTOMATIQUE

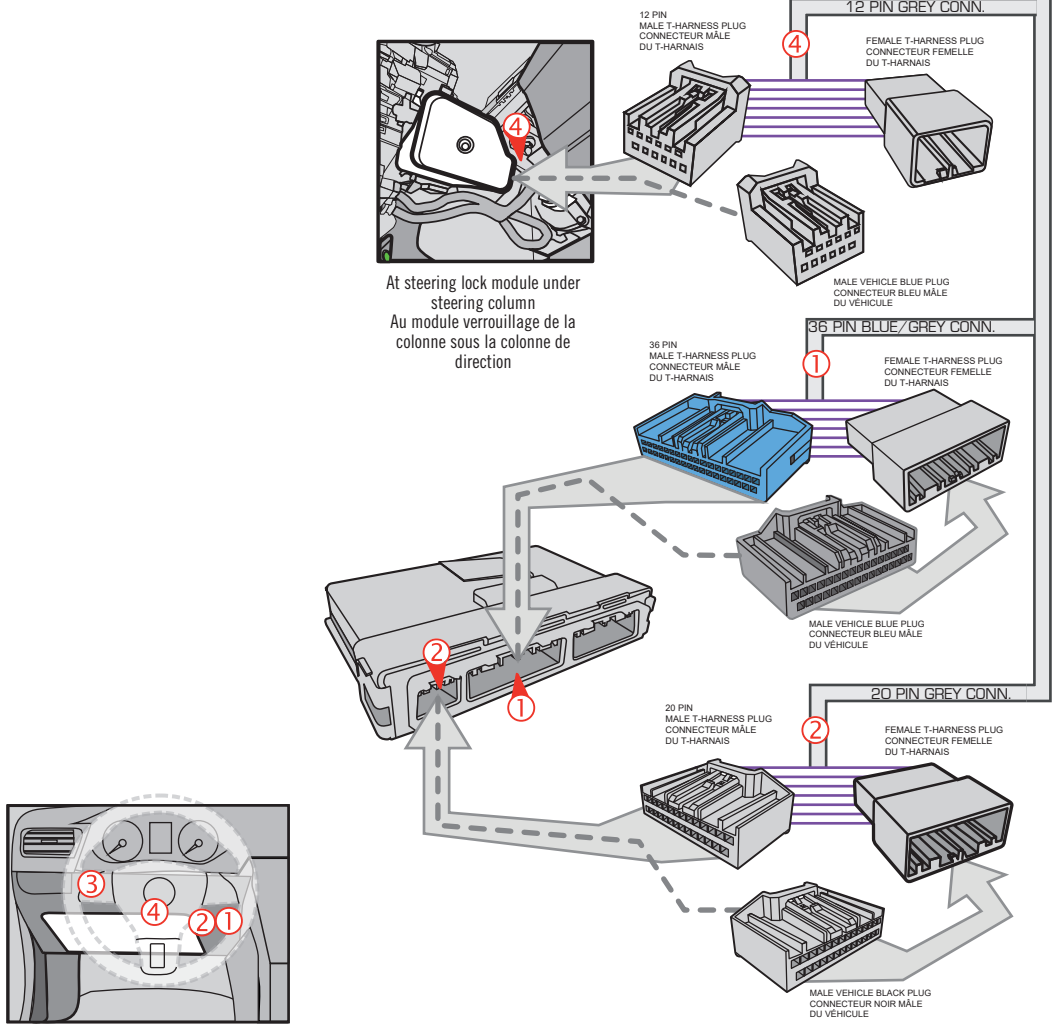
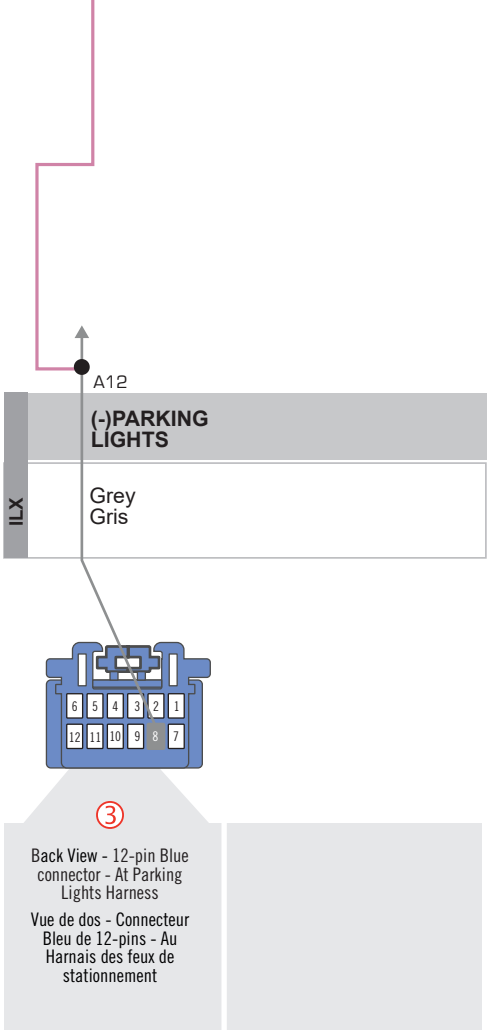
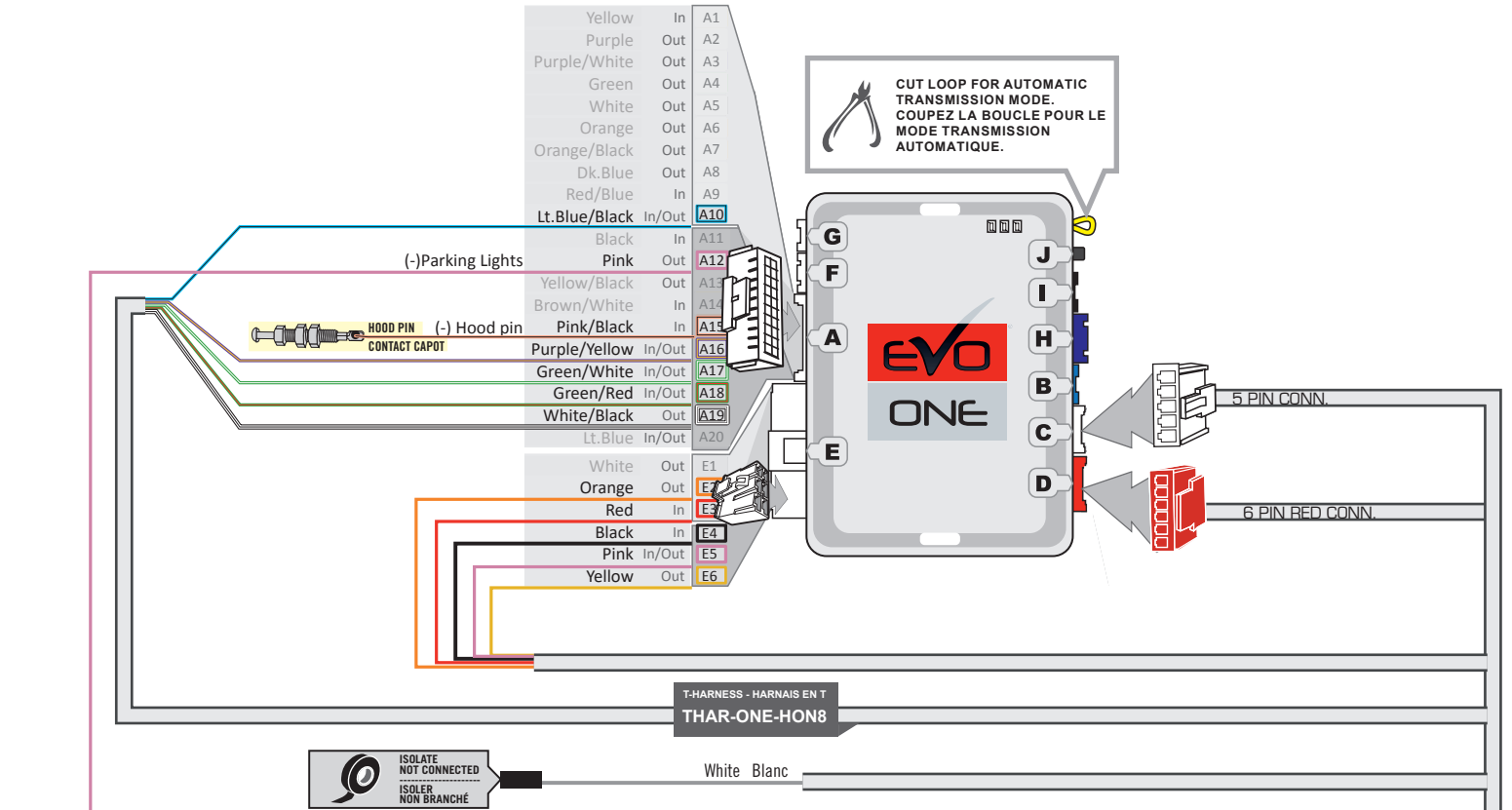

**THAR-ONE-HON8 | T-HARNESS - MANUAL TRANSMISSION | T-HARNAIS - TRANSMISSION MANUELLE**

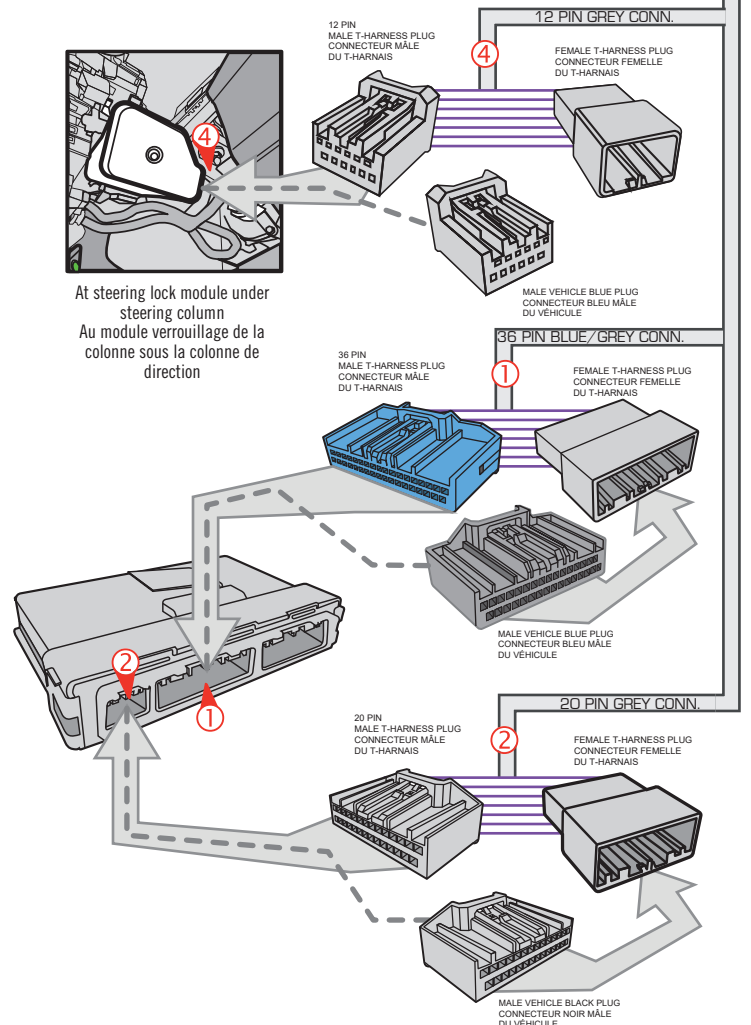
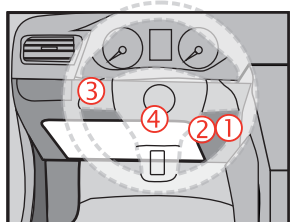
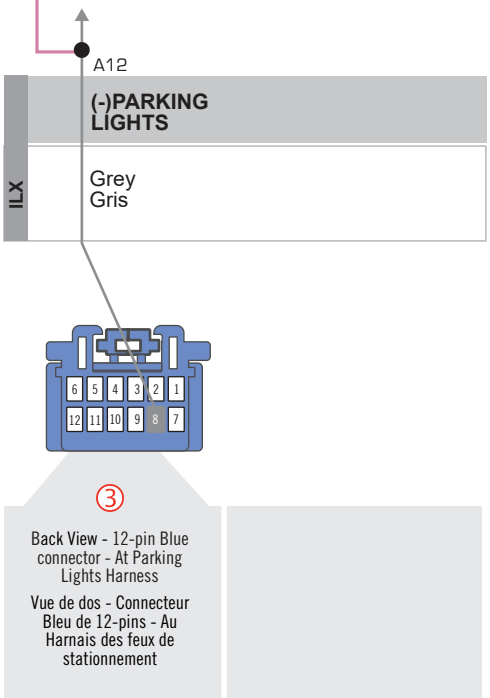
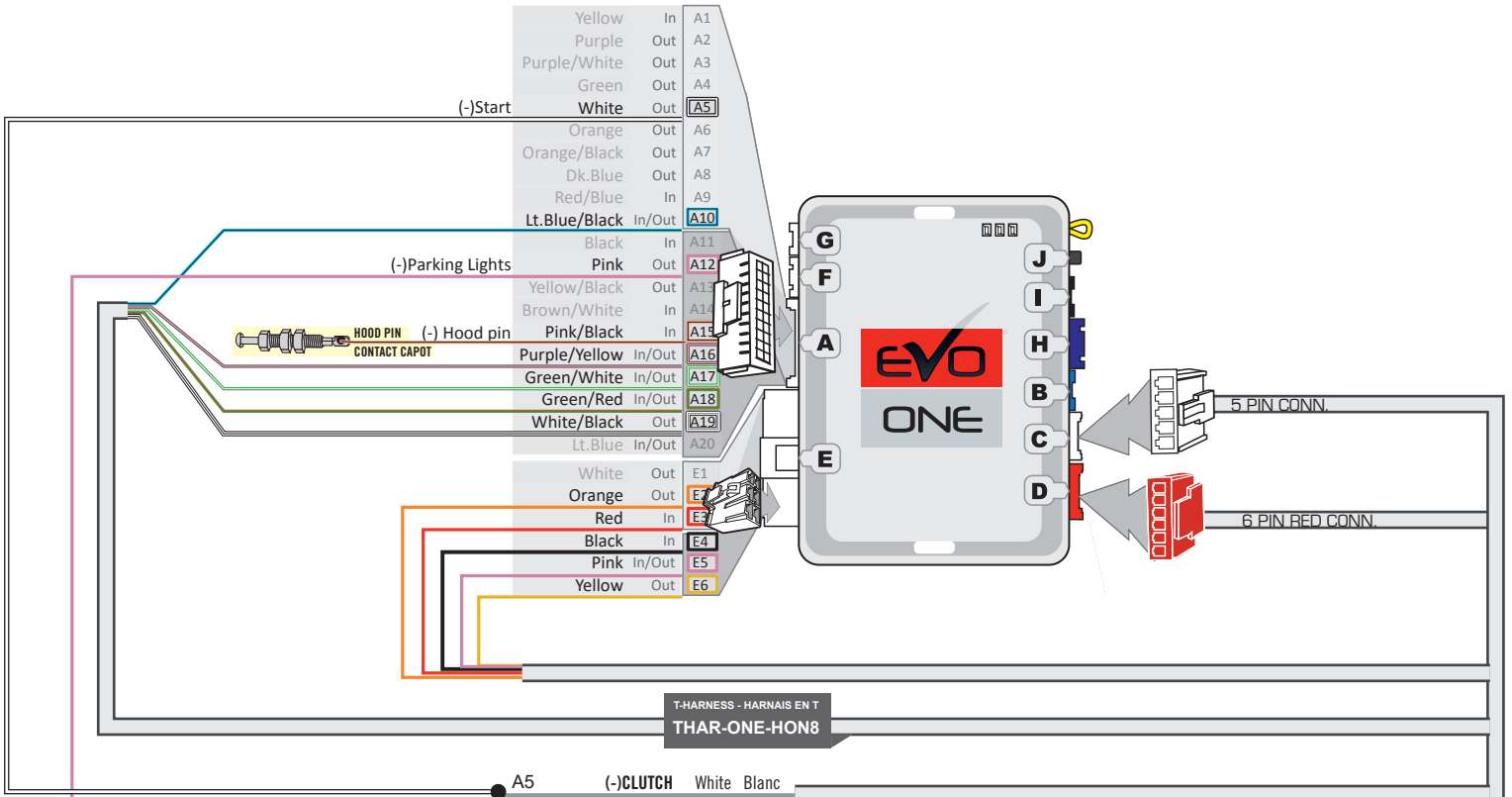

**DCRYPTOR PROGRAMMING PROCEDURE | PROCÉDURE DE PROGRAMMATION AVEC DCRYPTOR**



Parts required (not included) Pièces requises (non incluses)

- 1x **FLASH LINK UPDATER,**
- 1x **FLASH LINK MANAGER**  
SOFTWARE | PROGRAMME
- 1x Microsoft Windows Computer with Internet connection  
Ordinateur Microsoft Windows avec connection Internet

OR  
OU

- 1x **FLASH LINK MOBILE**
- 1x **FLASH LINK MOBILE APP**
- Smartphone Android or iOS with Internet connection  
(Internet provider charges may apply)  
Téléphone Intelligent Android ou iOS avec connection Internet (des frais du fournisseur Internet peuvent s'appliquer)

**BEFORE PROGRAMMING SET THE UNIT OPTIONS AND SAVE. | AVANT LA PROGRAMMATION CONFIGURER LES OPTIONS DE L'UNITÉ ET SAUVEGARDER.**

1

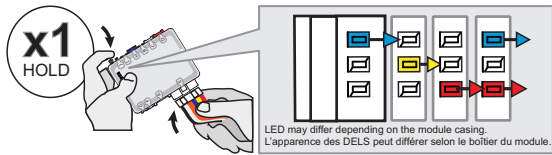

Press and hold the programming button:  
**Connect** the 6-PIN Main harness (White connector).  
↳ The Blue, Red, Yellow and Blue & Red LEDs will alternately illuminate.

**Appuyez et maintenir** le bouton de programmation enfoncé:  
**Branchez** le harnais Principal à 6-Pins (connecteur Blanc)  
↳ Les DELs Bleue, Rouge, Jaune et Bleue & Rouge s'illumineront alternativement.

2

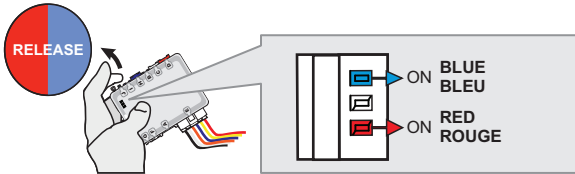

**Release** the programming button when the Blue & Red LEDs are ON.

**Relâchez** le bouton de programmation quand les DELs Bleue & Rouge sont allumées.

If the Blue & Red LEDs are not ON solid **disconnect** the 6-PIN Data-Link and go back to step 1.

If the Blue & Red LEDs are not ON solid **débranchez** le harnais Data-Link à 6-Broches et retournez au début de l'étape 1.

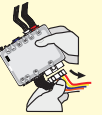

3

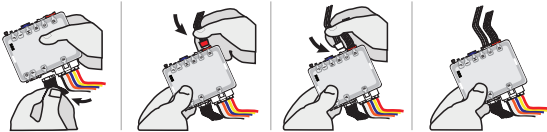

**Connect** the required remaining harnesses.

**Branchez** les harnais requis restants.

4

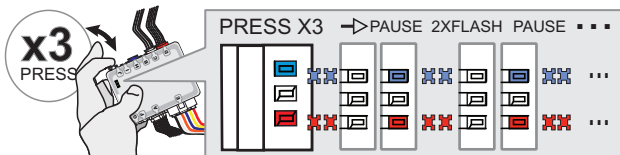

**Press and release** the programming button three times (3x).

↳ The Red and Blue LEDs will alternate between 2 flashes and a pause.

**Appuyez et relâchez** 3 fois le bouton de programmation.

↳ Les DELs Bleue et Rouge alterneront entre 2 clignotements et 1 pause.

5

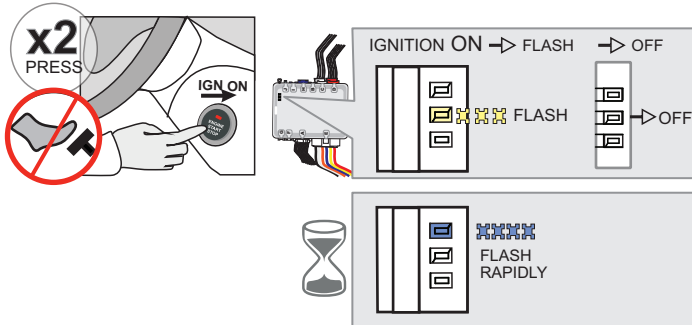

Do not press the brake pedal. **Press** the Push-to-Start button twice to turn ON the ignition.

↳ Wait for the Yellow Led to flash rapidly.

↳ Wait for the Blue LED to flash rapidly.

Ne pas appuyer sur le pédale de frein.

**Appuyez** 2 fois sur le bouton démarrage (Push-to-Start) pour allumer l'ignition.

↳ Attendez que la DEL Jaune clignote rapidement.

↳ Attendez que la DEL Bleue clignote rapidement.

6

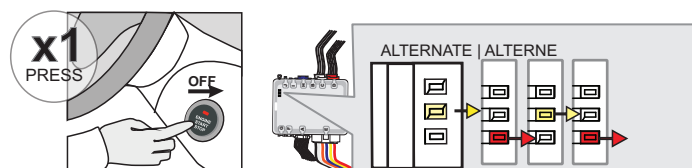

**Press** the Push-to-Start button once to turn OFF the ignition.

↳ The Red and Yellow LEDs will start flashing alternately.

**Appuyez** 1 fois sur le bouton démarrage (Push-to-Start) pour éteindre l'ignition.

↳ Les DELs Rouge et Jaune clignoteront alternativement.

**KEY BYPASS PROGRAMMING PROCEDURE 2/2 | PROCÉDURE DE PROGRAMMATION CONTOURNEMENT DE CLÉ 2/2**

7

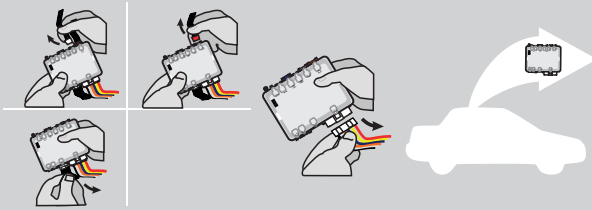

**Disconnect** all connectors and after the 6-Pin (Main-Harness) or the 4-Pin Data-link connector.

**Débranchez** tous les connecteurs et ensuite le connecteur 6-pins (Connecteur principal) ou le connecteur 4-pins (Data-Link).

8

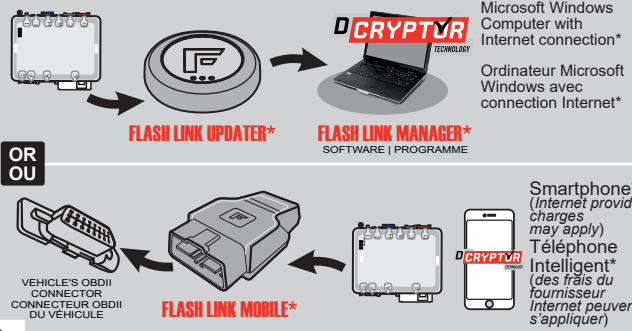

Microsoft Computer with Internet connection\*  
Ordinateur Microsoft Windows avec connection Internet\*

OR  
OU

Smartphone\* (Internet provider charges may apply)  
Téléphone Intelligent\* (des frais du fournisseur Internet peuvent s'appliquer)

**Use the tool: FLASH LINK UPDATER or FLASH LINK MOBILE** to visit the DCRaptor menu.

**Utilisez l'outil: FLASH LINK UPDATER ou FLASH LINK MOBILE** pour visiter le menu DCRaptor.

\*Parts required (not included) \*Pièces requises (non incluses)

9

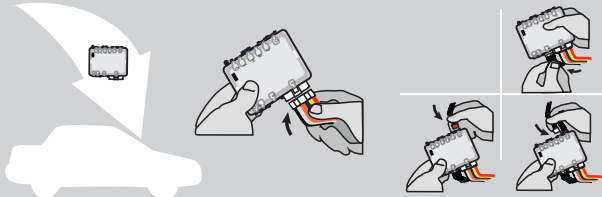

**AFTER DCRYPTOR PROGRAMMING COMPLETED**  
**Go back to the vehicle and reconnect** the 6-Pin (Main-Harness) or the 4-pins (Data-Link) connector and after all the remaining connector.

**APRÈS LA PROCÉDURE DE PROGRAMMATION DCRYPTOR COMPLÉTÉE :** retournez au véhicule et rebranchez le connecteur 6-pins (Connecteur principal) ou le 4-pins (Data-Link) et après tous les connecteurs.



The module is now programmed.  
Le module est programmé.



**REMOTE STARTER / ALARM VERIFICATION PROCEDURE | PROCÉDURE DE VÉRIFICATION DU DÉMARREUR À DISTANCE / ALARME**

Test the remote starter. Remote start the vehicle.  
Testez le démarreur à distance. Démarrez le véhicule à distance.





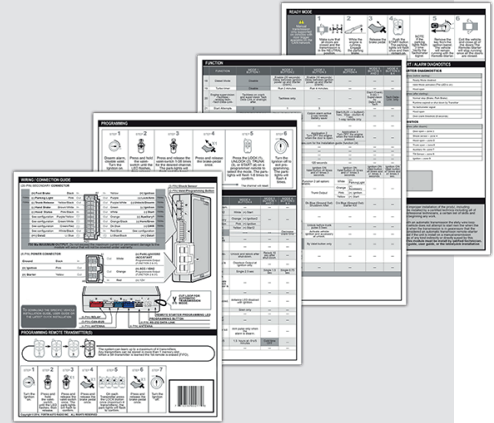

**REMOTE STARTER PROGRAMMING PROCEDURE | PROCÉDURE DE PROGRAMMATION DU DÉMARREUR À DISTANCE**

 REFER TO THE **QUICK INSTALL GUIDE** INCLUDED WITH THE MODULE FOR THE REMOTE STARTER PROGRAMMING.

 RÉFÉREZ-VOUS AU **GUIDE D'INSTALLATION RAPIDE** INCLUS AVEC LE MODULE POUR LA PROGRAMMATION DU DÉMARREUR À DISTANCE.

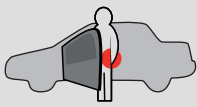

**REMOTE STARTER FUNCTIONALITY | FONCTIONNALITÉS DU DÉMARREUR À DISTANCE**

 <p>All doors must be closed. Toutes les portes doivent être fermées</p>  <p>Start Remote start the vehicle. Démarrez à distance.</p>	 <p>UNLOCK</p> <p>Unlock the doors with either:</p> <ul style="list-style-type: none"> <li>• The OEM remote</li> <li>• The remote-starter remote</li> </ul> <p>• Or the proximity remote</p> <p>Déverrouillez les portes avec soit:</p> <ul style="list-style-type: none"> <li>• la télécommande d'origine</li> <li>• la télécommande du démarreur à distance</li> <li>• ou la télécommande de proximité.</li> </ul>	 <p>Enter the vehicle with the SMART-KEY. Entrez dans le véhicule avec la clé intelligente (SMART-Key) sur vous</p>	 <p>x1 PRESS</p> <p>DO NOT PRESS THE BRAKE PEDAL. Press and release the Push-to-Start button once. NE PAS APPUYER LA PÉDALE DE FREIN. Appuyez et relâchez une fois le bouton démarrage (Push-to-Start).</p>	 <p>Press the brake pedal. The vehicle can now be put in to gear and driven. If the Smart-Key is not detected the vehicle will shut down. Appuyez sur la pédale de frein. Vous êtes maintenant prêt à embrayer et prendre la route. Si la clé intelligente n'est pas détectées le véhicule s'éteindra.</p>
---	---	--	---	---

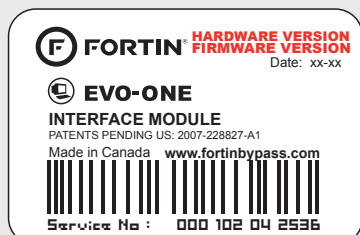

Module label | Étiquette sur le module

### Notice: Updated Firmware and Installation Guides

Updated firmware and installation guides are posted on our web site on a regular basis. We recommend that you update this module to the latest firmware and download the latest installation guide(s) prior to the installation of this product.

### Notice: Mise à jour microprogramme et Guides d'installations

Des mises à jour du Firmware (microprogramme) et des guides d'installation sont mis en ligne régulièrement. Vérifiez que vous avez bien la dernière version logiciel et le dernier guide d'installation avant l'installation de ce produit.

## WARNING

The information on this sheet is provided on an (as is) basis with no representation or warranty of accuracy whatsoever. It is the sole responsibility of the installer to check and verify any circuit before connecting to it. Only a computer safe logic probe or digital multimeter should be used. FORTIN ELECTRONIC SYSTEMS assumes absolutely no liability or responsibility whatsoever pertaining to the accuracy or currency of the information supplied. The installation in every case is the sole responsibility of the installer performing the work and FORTIN ELECTRONIC SYSTEMS assumes no liability or responsibility whatsoever resulting from any type of installation, whether performed properly, improperly or any other way. Neither the manufacturer or distributor of this module is responsible of damages of any kind indirectly or directly caused by this module, except for the replacement of this module in case of manufacturing defects. This module must be installed by qualified technician. The information supplied is a guide only. This instruction guide may change without notice. Visit [www.fortinbypass.com](http://www.fortinbypass.com) to get the latest version.

## MISE EN GARDE

L'information de ce guide est fournie sur la base de représentation (telle quelle) sans aucune garantie de précision et d'exactitude. Il est de la seule responsabilité de l'installateur de vérifier tous les fils et circuits avant d'effectuer les connexions. Seuls une sonde logique ou un multimètre digital doivent être utilisés. FORTIN SYSTÈMES ÉLECTRONIQUES n'assume aucune responsabilité de l'exactitude de l'information fournie. L'installation (dans chaque cas) est la responsabilité de l'installateur effectuant le travail. FORTIN SYSTÈMES ÉLECTRONIQUES n'assume aucune responsabilité suite à l'installation, que celle-ci soit bonne, mauvaise ou de n'importe autre type. Ni le manufacturier, ni le distributeur ne se considèrent responsables des dommages causés ou ayant pu être causés, indirectement ou directement, par ce module, excepté le remplacement de ce module en cas de défectuosité de fabrication. Ce module doit être installé par un technicien qualifié. L'information fournie dans ce guide est une suggestion. Ce guide d'instruction peut faire l'objet de changement sans préavis. Consultez le [www.fortinbypass.com](http://www.fortinbypass.com) pour voir la plus récente version.

Copyright © 2006-2018, FORTIN AUTO RADIO INC ALL RIGHTS RESERVED PATENT PENDING



## TECH SUPPORT

Tél: 514-255-HELP (4357)  
1-877-336-7797



## ADDENDUM GUIDE

[www.fortinbypass.com](http://www.fortinbypass.com)

WEB UPDATE | MISE À JOUR INTERNET

